

**NIESMANN
+ BISCHOFF**

ARTO



Clou inside

GB



CONTENTS

04	ON THE ROAD WITH THE ARTO
28	CLOU: THE STAR ATTRACTION
30	A LOOK INSIDE THE ARTO

JOIN US ON A VOYAGE OF
DISCOVERY.







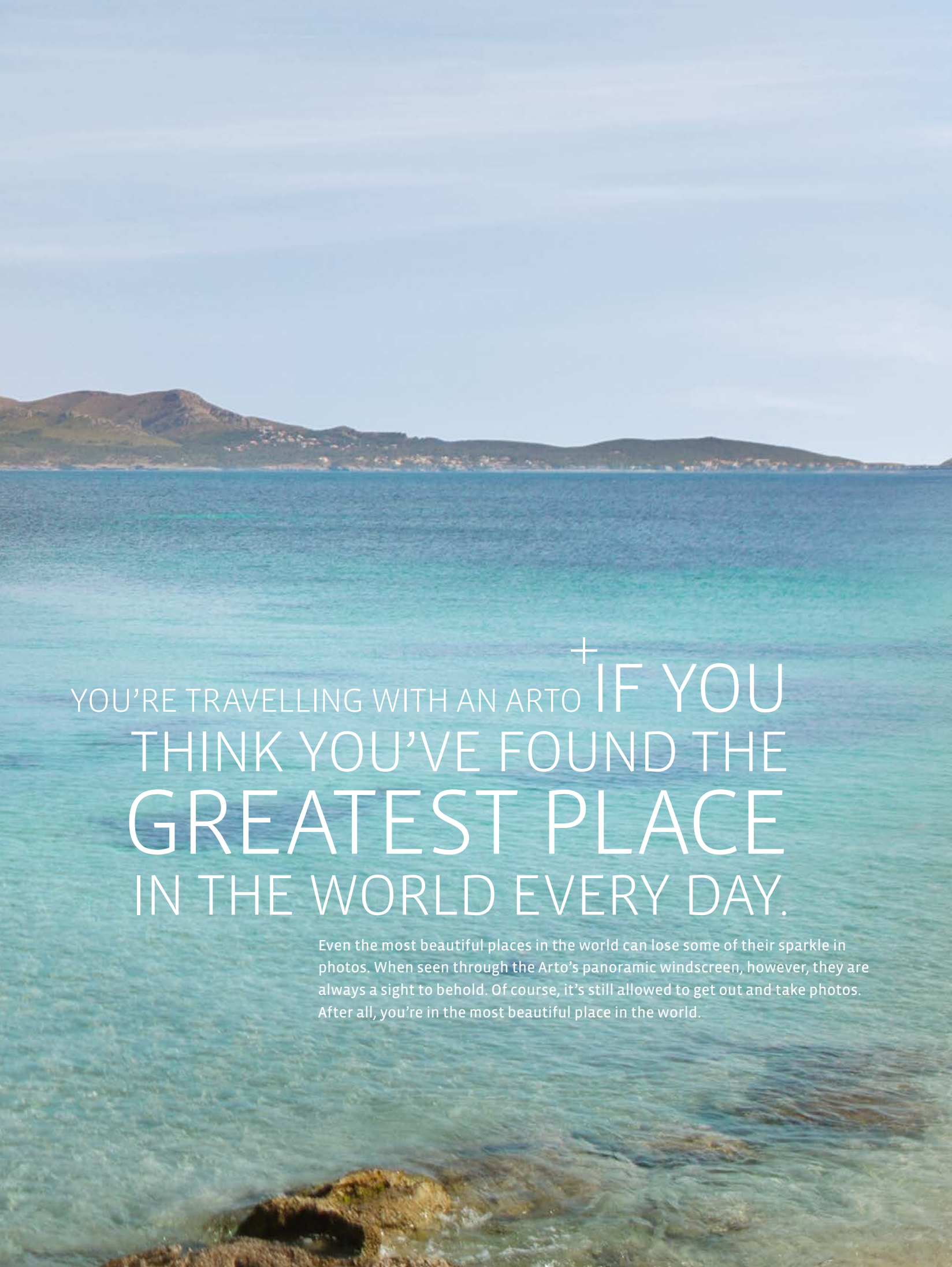

YOU'RE TRAVELLING WITH AN ARTO + IF YOU
THINK YOU'VE FOUND THE
GREATEST PLACE
IN THE WORLD EVERY DAY.

Even the most beautiful places in the world can lose some of their sparkle in photos. When seen through the Arto's panoramic windscreen, however, they are always a sight to behold. Of course, it's still allowed to get out and take photos. After all, you're in the most beautiful place in the world.









YOU'RE TRAVELLING WITH AN ARTO⁺ IF THE DAY GETS OFF TO A REALLY GREAT START.

You've been on holiday for two days and left the stove on? And the tap and coffee machine, too? Good, then breakfast should almost be ready. Unless you forgot to heat up the bread rolls. We've got an idea for just this occasion – simply lock up all the cupboards with a single flick of the wrist and rush to the nearest bakery.





YOU'RE TRAVELLING WITH AN ARTO ⁺ IF
YOU'VE ALREADY SEEN SOME
OF THE WORLD WITH YOUR
FIRST SIP OF
COFFEE.

Whether you're in Sweden or Spain, the perfect day starts off the same everywhere – with a cup of coffee and a fresh newspaper in the cosy living area of an Arto. And as the world keeps moving, just turn the driver's seat around and spend a relaxing morning at the breakfast table.





YOU'RE TRAVELLING WITH AN ARTO ⁺ IF
THE BEST WAY
IS NOT ALWAYS THE SHORTEST WAY.

Hopefully you've had a good breakfast so you can master the serpentine roads just as easily as the Arto. The amazing views from the top will be well worth it. Or you may well discover another one of those places you weren't looking for, but will never ever forget.





A herd of sheep, including several lambs, is shown in a lush, green forest. The sheep are in the foreground, some looking towards the camera, while the background is filled with dense foliage and trees. The lighting is soft and natural, suggesting a sunny day with some shade.

YOU'RE TRAVELLING WITH AN ARTO⁺ IF YOU DON'T
NEED TO MOVE IN ORDER
TO ARRIVE.

For us, luxury means having all the time in the world and spending it in the most beautiful corners of the planet. Ideally, with one of the best liners in the world. Our Arto offers you a high level of comfort at all times. It's a holiday before you even hit the road.





YOU'RE TRAVELLING WITH AN ARTO ⁺ IF THE
CHIRPING OF CRICKETS
IS THE MOST PEACEFUL SOUND
YOU CAN IMAGINE.

Nothing beats a parking spot with a sea view. Except perhaps a parking spot beside old olive trees. Or by a lapping stream, while the sound of cowbells gently fills the air. Our favourite places are all different, but they have one thing in common – we remember them with all of our senses. And if we should feel a sense of longing, we can happily return there any time with an Arto. Or simply discover a new favourite place.



A man in a white shirt and dark shorts stands in a field of tall grass next to an open Arto van. A dog is sitting in the grass to his right. The background shows a lush, green landscape with trees and a bright sky. The text is overlaid on the top left of the image.

YOU'RE TRAVELLING WITH AN ARTO ⁺IF
THE DAY IS MADE
OF MOMENTS

RATHER THAN HOURS.

Only when you can no longer tell what day it is have you reached your destination – independence from time and space. This feeling sets in quickly with an Arto. When exactly, no one can say. Maybe on a Tuesday?



YOU'RE TRAVELLING WITH AN ARTO + IF YOU CAN
CHANGE THE CUSHION COVERS
AS EASILY AS
THE TRAVEL ROUTE.

Travelling in an Arto means being independent in every way. Just as you don't need to spend every holiday in France, you also don't need to have the same cushion combinations in your living room for every holiday. You can change them whenever you like - but you don't have to. And you can continue going to France every year, too.







YOU'RE TRAVELLING WITH AN ARTO ⁺ IF
GOOD WEATHER
IS SOMETIMES BAD WEATHER.

Why not spend the next day relaxing in bed? Keep your feet up, make some progress with that paperback, grab a coffee now and then, and then get back to it. But no, the sun is shining again – for days now. Maybe next year, you'll just travel north. For some real stay-in-bed weather.

YOU'RE TRAVELLING WITH AN ARTO⁺ IF YOU CAN SLEEP JUST AS WELL ON STONES.

With an Arto, you are finally one of those enviable people who can sleep well anywhere. In the city or in the mountains, power napping in front of the television, or through the night in the bedroom. Just draw the curtains, pull down the blinds and put everything out of your mind. Good night and good morning!







CLOU: + THE STAR ATTRACTION.

More than 30 years ago, we at Niesmann+Bischoff launched our first motorhome on the market. We called it Clou, as though we already had a clue of what was to come. As a motorhome, it was unprecedented on the market. The Clou was filled with ideas still unique at the time and which quickly led to imitations. With its special solutions that caused a sensation, it won many fans in the industry.

Nothing has changed. Day by day, and model by model, we are looking for new solutions that make travelling in a liner an unforgettable experience. We live by these ideas, they show us the way and they make all the difference. They are simply the Clou - ideas no else has even considered before. Our Clou will delight you on every trip you take with a Niesmann+Bischoff, whether you choose to hit the road in an Arto or a Flair. Both are star attractions: both have the Clou inside.



Clou inside

THERE IS ALWAYS SPACE FOR GREAT IDEAS.

We're architects. Over an area of approximately 16 to 20 square metres, we have made you an entire home, with a cosy living room, a large bathroom, a kitchen that has everything you need and a bedroom made with the fabric of dreams. For this, we need to call on many great solutions. We invite you to our world of ideas, to a journey together through the interior of your new Arto.

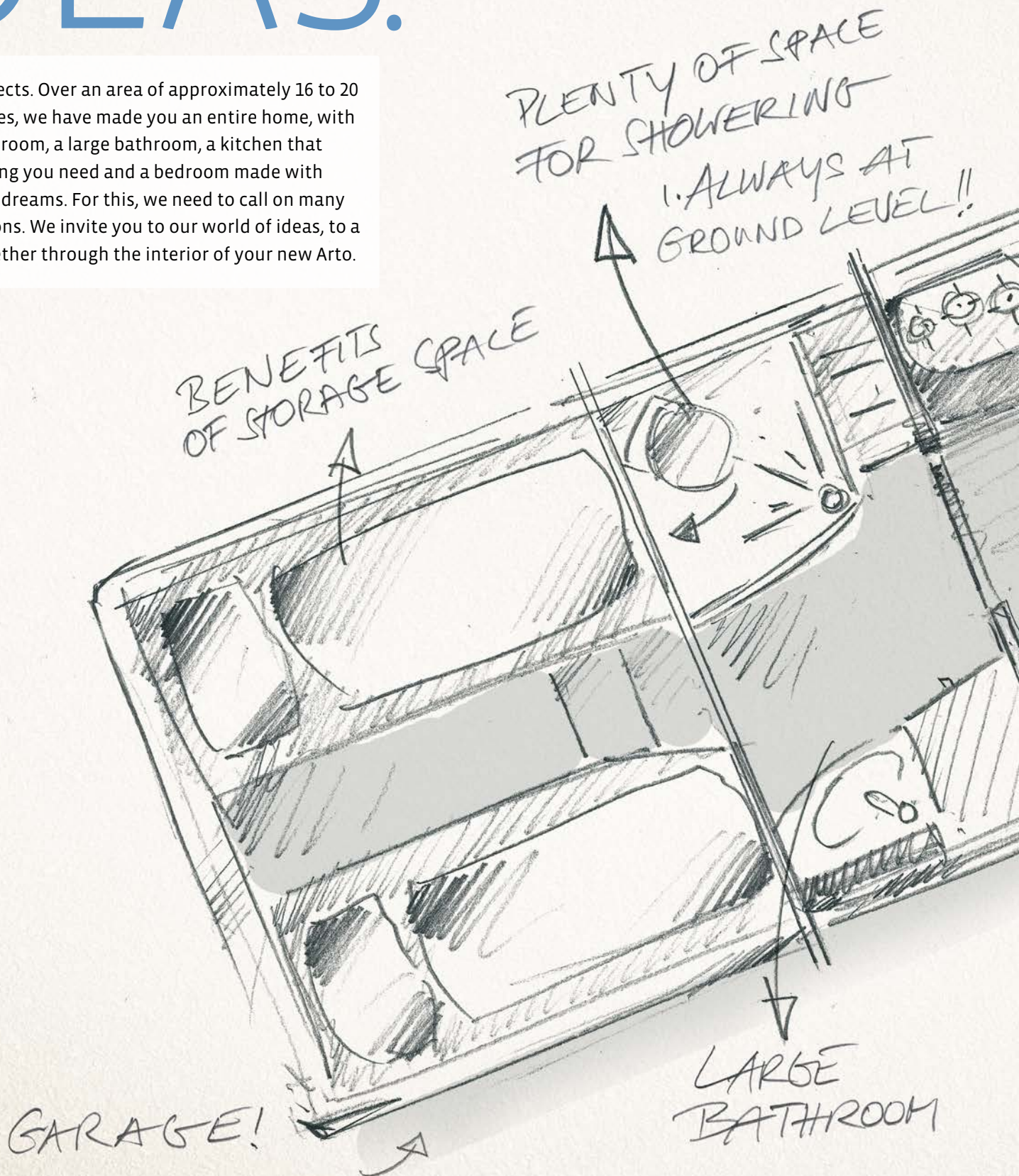

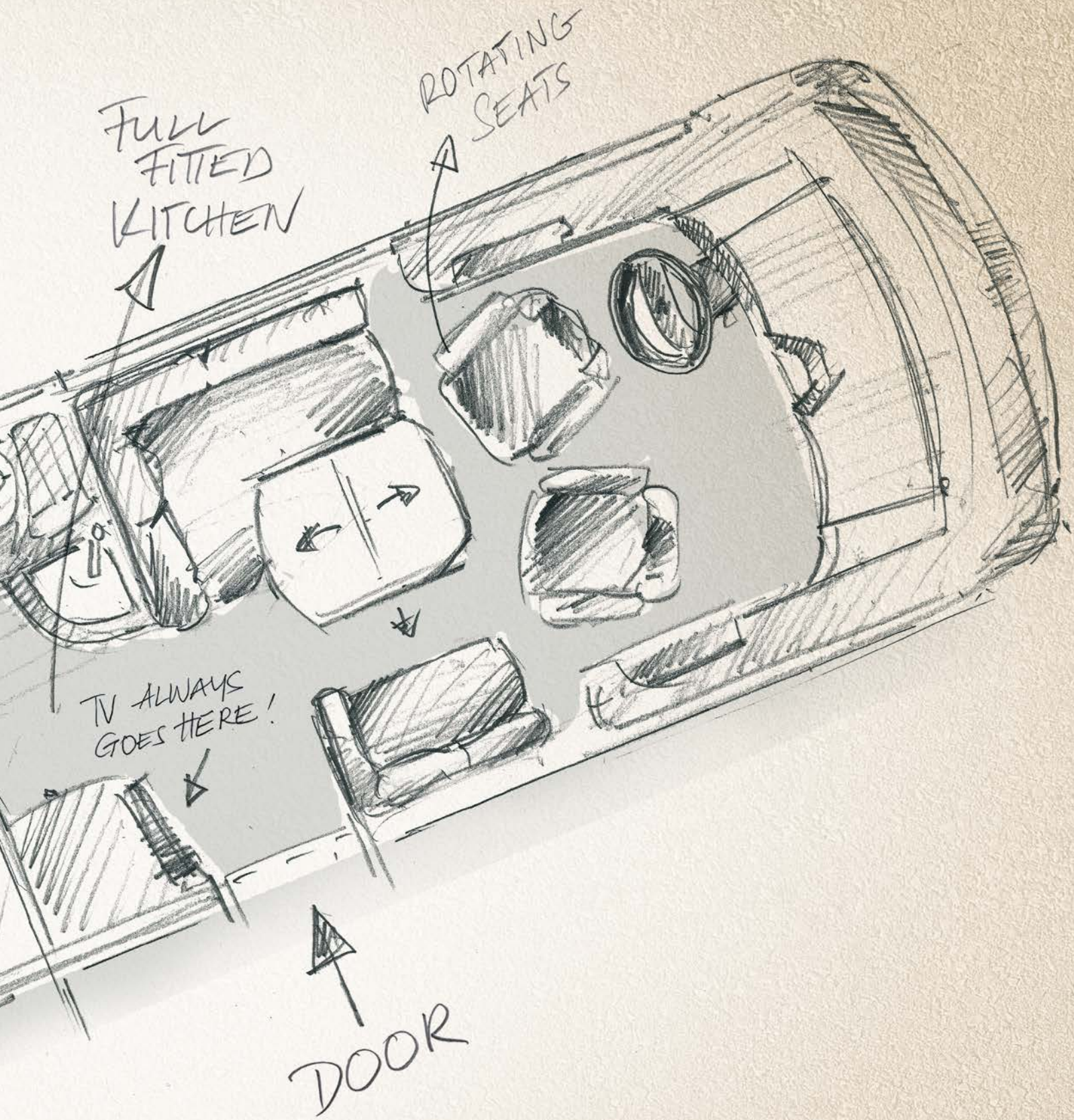

FULL
FITTED
KITCHEN

ROTATING
SEATS

TV ALWAYS
GOES HERE!

DOOR



TRAVELLING MEANS FREEDOM. + IN THE INTERIOR, TOO.

Travelling with an Arto means freedom. And this freedom begins on the inside. When you're relaxing in your Arto and enjoying the view, it shouldn't end at the first partition wall before the kitchen. Thanks to our idea of retractable belt supports, it doesn't have to. This allows us to remove this wall completely and create a totally different sense of space. Now you can enjoy the luxury of unlimited freedom in each of our liners. Sometimes things need to be left out to achieve maximum comfort, whatever the cost.



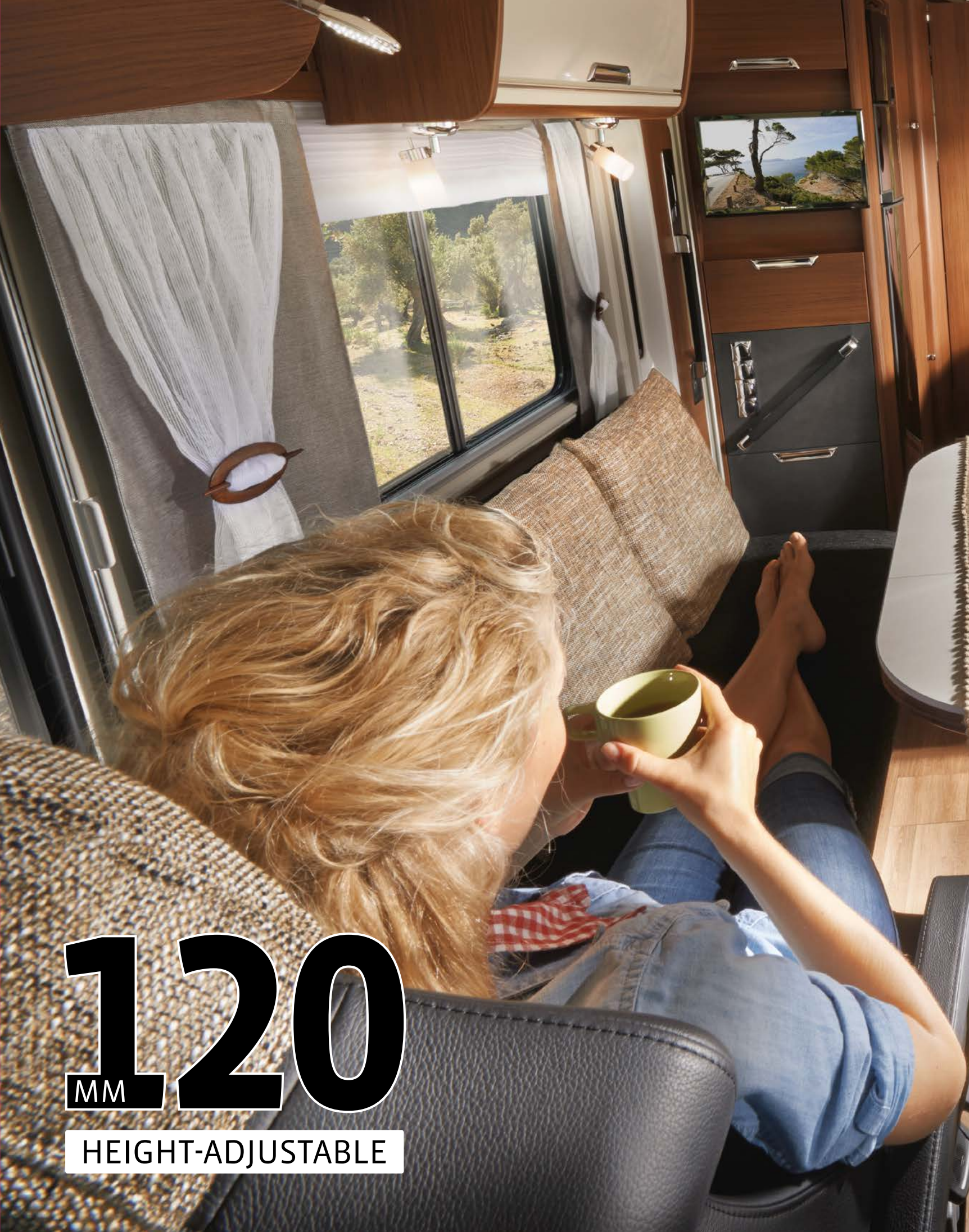

120
MM

HEIGHT-ADJUSTABLE



180°

ROTATING SEATS

HOW A DRIVER'S SEAT BECOMES A RECLINER.

What's the difference between two comfortable, ergonomic driver's and passenger seats and two cosy recliners? Exactly 180 degrees, the optional SKA seats in a Niesmann+Bischoff can be whichever you want. As driver's seats, they offer you support on long journeys and can be adjusted for the specific needs of every part of your body.

And when you feel the need to take a break and recharge your batteries, just spin the seat 180 degrees around until it locks in place, and adjust the height so you can rest your legs on the sofa in front of you. Now just fold your arms behind your head and enjoy a relaxing evening in front of the television.



ca. 14

SQUARE METRES

THE MOST IMPORTANT INGREDIENTS IN OUR KITCHEN? GOOD IDEAS.

If you want to fit an oven, fridge, freezer, one sink, three gas hobs, as many drawers as possible and even more, all within an area of just one-and-a-half square metres, you need to draw on a wealth of excellent ideas. At Niesmann+Bischoff, we have them in abundance. Everything is there, so you've got all you need, even on your holiday. The kitchen still manages to look spacious, as every detail has its own individual place. And to keep it this way, you can lock up and secure all the cabinets in the kitchen using a single switch.







WE DON'T HAVE ROOM FOR SMALL BATHROOMS.

With an array of ideas both large and small, we at Niesmann+Bischoff have ensured that you can enjoy an exceptionally large bathroom area with ample freedom of movement in each of our motorhomes. Enjoy the luxury of well-being within your own four walls, with the added benefit that these walls are all particularly far apart.

A LONG, LUXURIOUS SHOWER IS CALLING.

After a long, relaxing lie in the sun, there's no better feeling on holiday than stepping into the large and luxurious shower in a Niesmann+Bischoff. Each of our models dedicates a lot of space to the bathroom. Then you've got yourself a large shower tray. And a large wellness area in your Arto.

11.3

ca.

LITRES PER MINUTE

Another bathroom highlight may not be immediately obvious. The high-quality pressure pump operates very quietly and evenly at a constant water pressure. The only place you can enjoy such a comfortable shower is at home or in a Niesmann+Bischoff.



To create as much space for showering as possible, even in smaller areas, the swivel toilet can be stowed away into the wall with a simple flick of the wrist.







OTHERS CAN ONLY DREAM OF THIS MUCH STORAGE SPACE.

We have found space where others have not even thought of looking. The bedroom in a Niesmann+Bischoff has all you need for a restful night and a sound sleep on an exceptional bed system.

THE BEST MATERIAL FOR YOUR HOLIDAY ADVENTURES.

We keep developing new ideas to make our vehicles even better. But sometimes we return to old inspiration – we only use the very best materials for our furnishings.



Scratch-proof 3D leaf lends a high-quality wooden look to the furniture and cabinets.



The sturdy door with high-quality fittings separates the bedroom and bathroom from the living area. All the key fittings and hinges in the Arto are made of metal, so they will close securely and never wear.



We only use robust glass-reinforced plastic for the shower tray, so it is extremely wear and scratch-resistant.

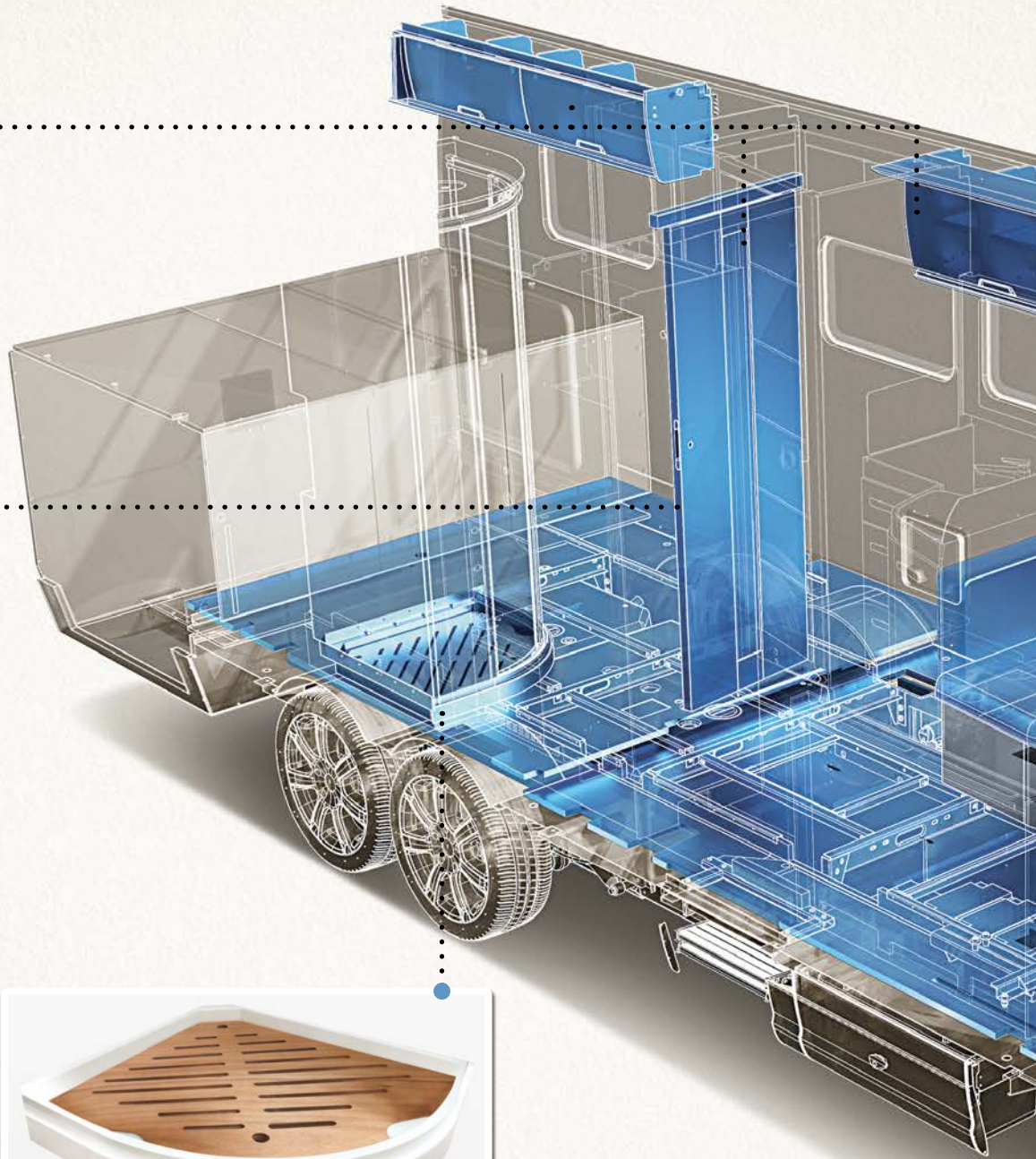

Thanks to our push-to-open latches, we can manage without knobs on many doors, as these can loosen through frequent pulling and pushing. With the latest hydraulic lifting technology, the upper cabinets open and close quietly and conveniently.



50.000

ABRASION CYCLES



The three-layer foam concept ensures sitting on the sofa is always comfortable; 50,000 abrasion cycles testify to the long lifespan of the covers. A gap in the upholstery ensures convenient access to the storage space underneath.



The floor is particularly robust thanks to its vinyl coating with a wooden look and structure.

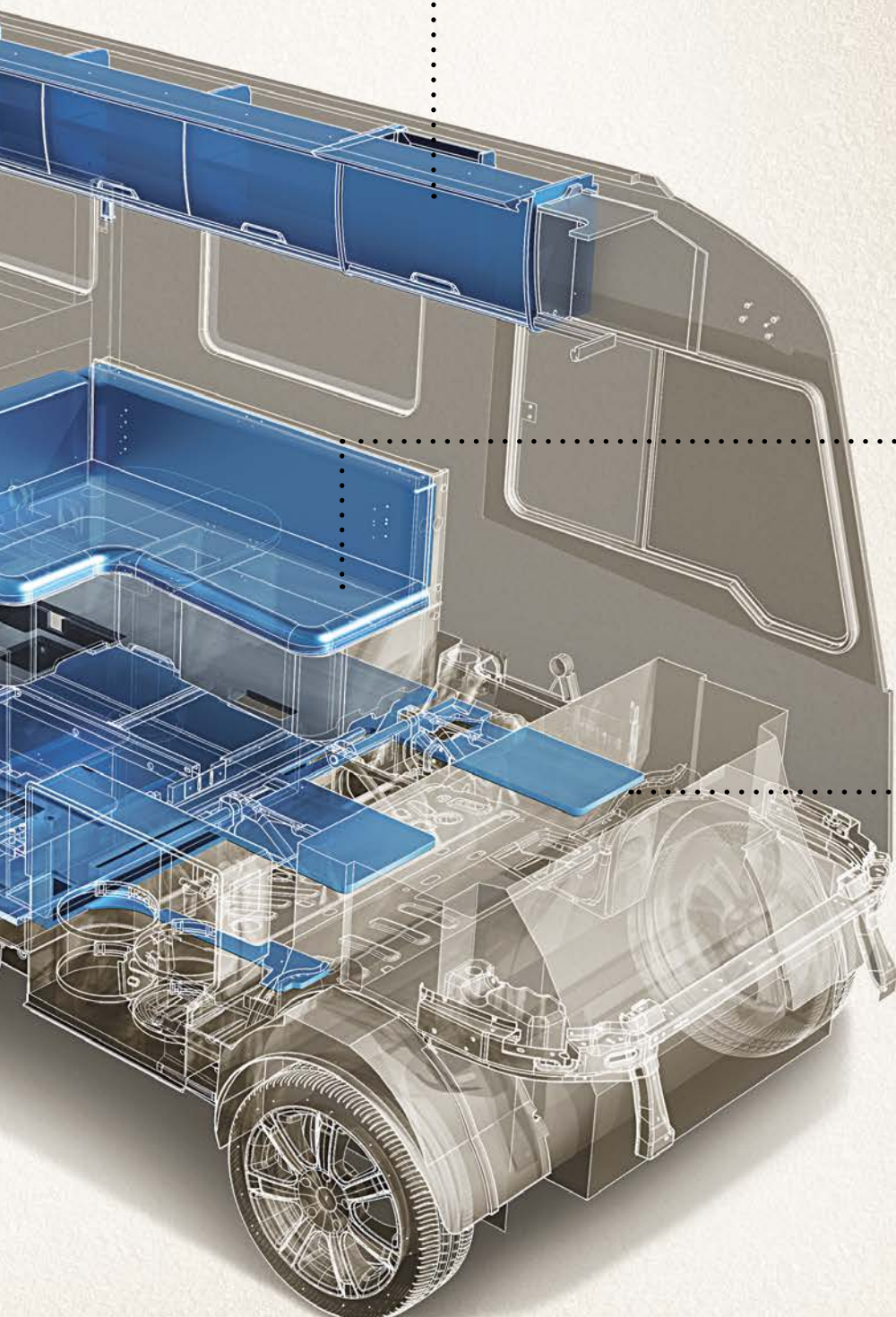



CHANGE THEM
WHENEVER YOU LIKE!

WE GIVE YOU COMPLETE FREEDOM.
INCLUDING THE FREEDOM TO MAKE
YOUR OWN DESIGNS.

+

When it comes to interior design, there is no one perfect solution. There are more than 500 to be precise, and each is correct. We give you complete freedom to make your own design. It's up to you now. Design your Arto just how you imagine a cosy home on the road should be. From more than 500 combinations, choose the one that suits you best. Scan the QR code to see some suggestions.



OVER
500

POSSIBILITIES









JUST LIKE THIS OR COMPLETELY DIFFERENT

You've made your decision. You've found the perfect combination for you. At Niesmann+Bischoff, you can have even more. Even more freedom. You can change the doors on the ceiling cupboards and the cushions in a snap. Swap them for your favourite combination or for that other one that you may like even more. With us, you can change your mind again and again.

CAN BE REPLACED
QUICKLY
AND SIMPLY.



RELAXING WITH STATE-OF-THE-ART TECHNOLOGY.

+

So we don't bore you with technical details over the following pages, we have simply fitted our Arto with as many interesting technological highlights as possible. And of course to offer you maximum security and comfort on your travels. Over the following pages, take a peek at what's going on behind the scenes of our comfort liner while you're enjoying your holiday.





The AL-KO low frame with super-broad gauge is modified so that the entire structure is lowered, including the Arto's centre of gravity. This effect is magnified by the large water tank in the tub of the double floor, as this lowers the centre of gravity a little bit more.

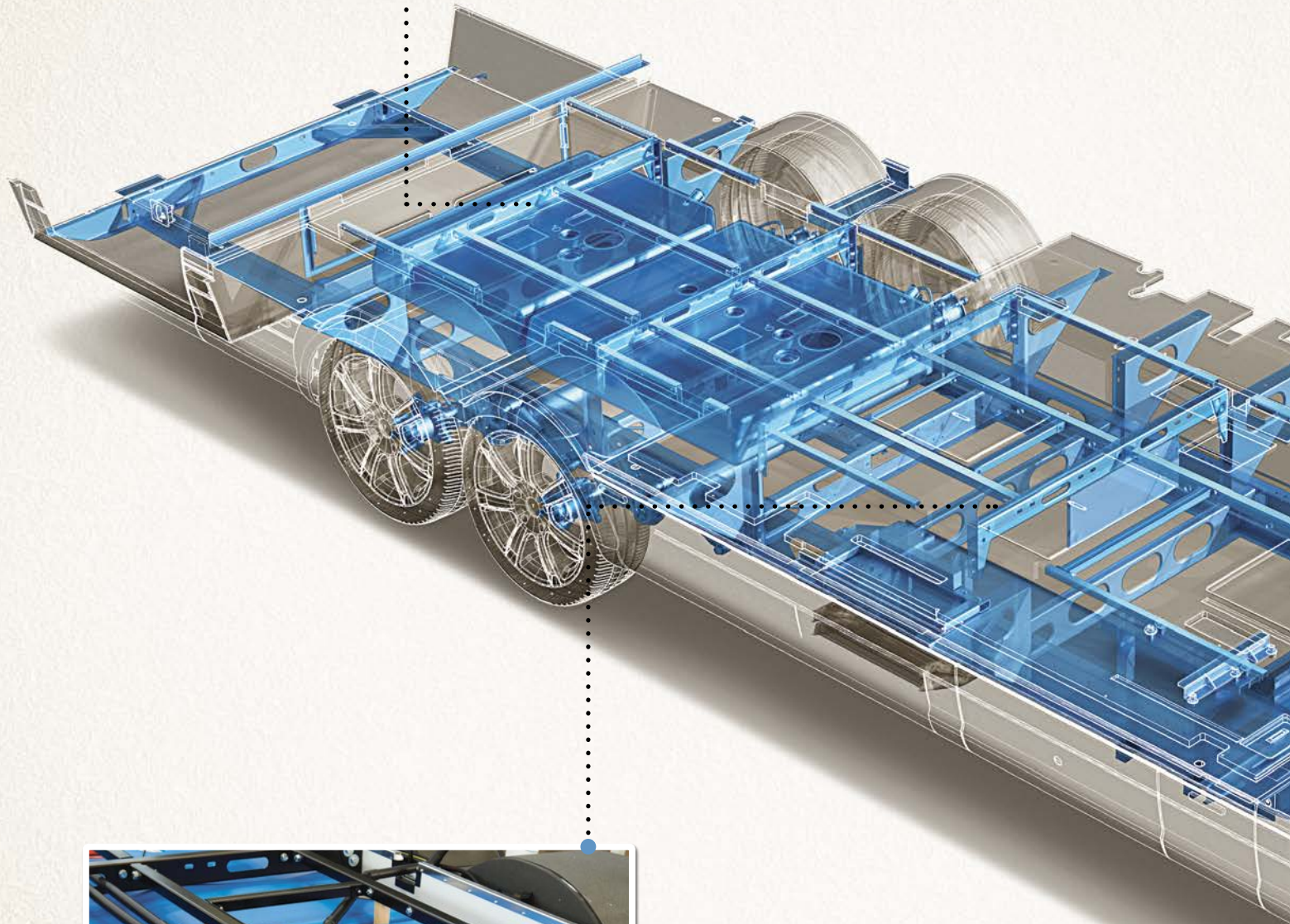

But if we want to offer a driving experience like in a car, we can't stop there. Our solution is securely fastened cross-bracing in the low frame. Quite complex, but particularly effective, as this gives the Arto a very special level of rigidity.

TRAVEL WITH THE FEELING OF DRIVING A CAR.

We want your holiday to begin before you even hit the road. This is why Niesmann+Bischoff luxury liners offer unique driveability. We have done everything in our power to ensure that the Arto drives better than a vehicle the size of a motorhome.

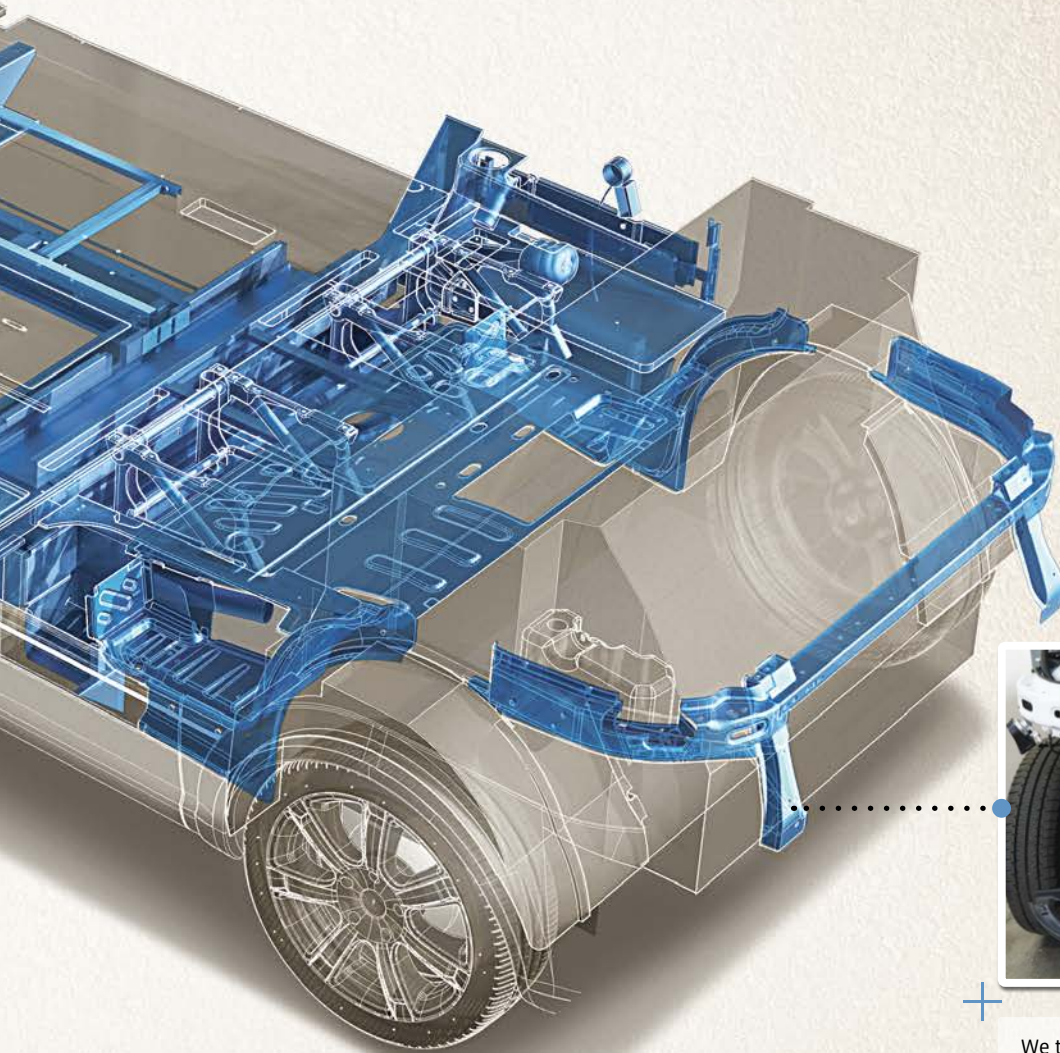

We take it as a given that both driver and passenger should have maximum protection while travelling. As a result, we have integrated the secure and certified crash box into our Niesmann+Bischoff design unmodified. Only then were we content.

WHEN IT COMES TO SERVICE, YOU'VE COME TO THE RIGHT PLACE WITH US.

Our motorhomes are extremely easy to service. Gas bottles, water tanks, batteries and access flaps for grey water and electricity are always in just the right place. Just where you need them.

Quick and easy access to the battery.



The spacious gas bottle box offers ample space for two gas bottles of up to 14 kg (even with collars).

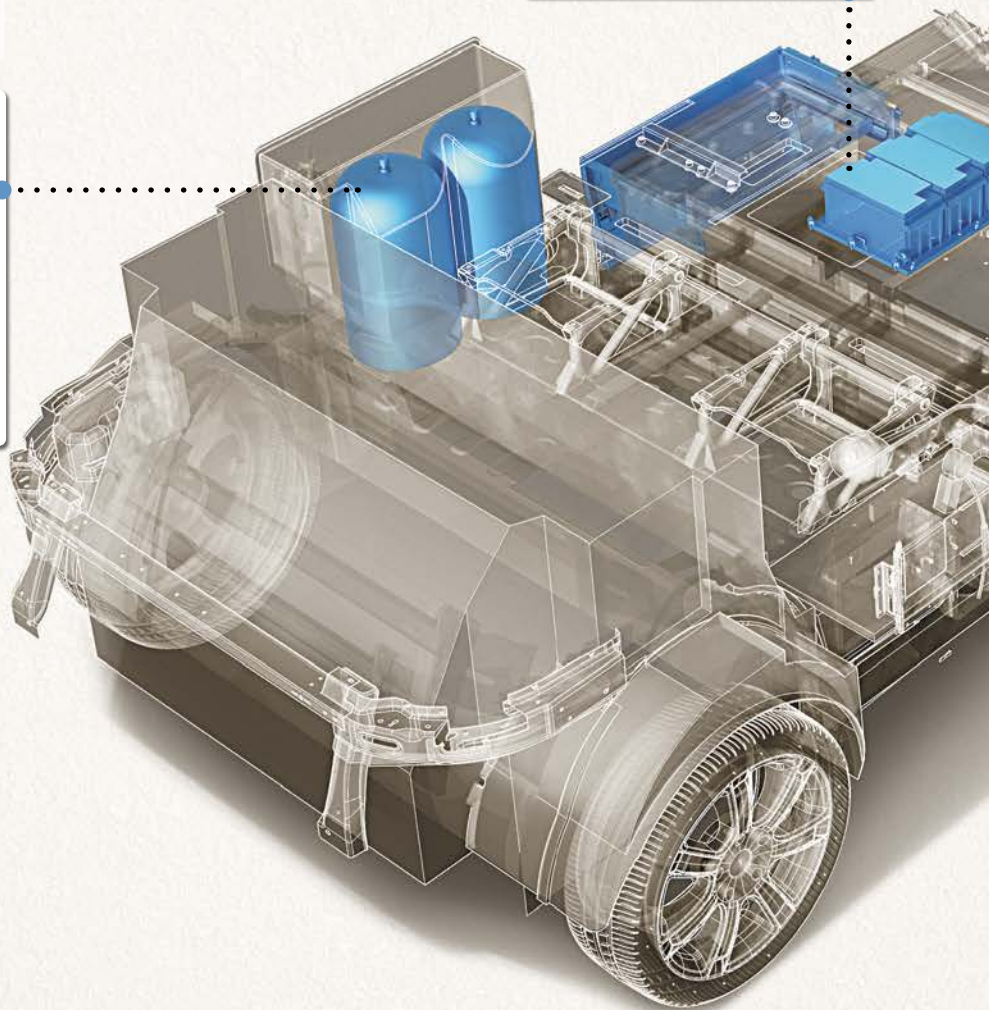
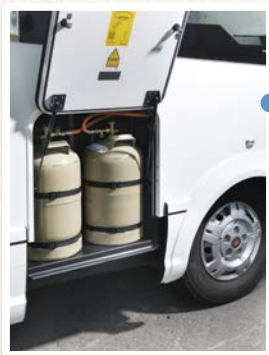

1.25 m high. The spacious rear garage for scooters, e-bikes or bulky packages.

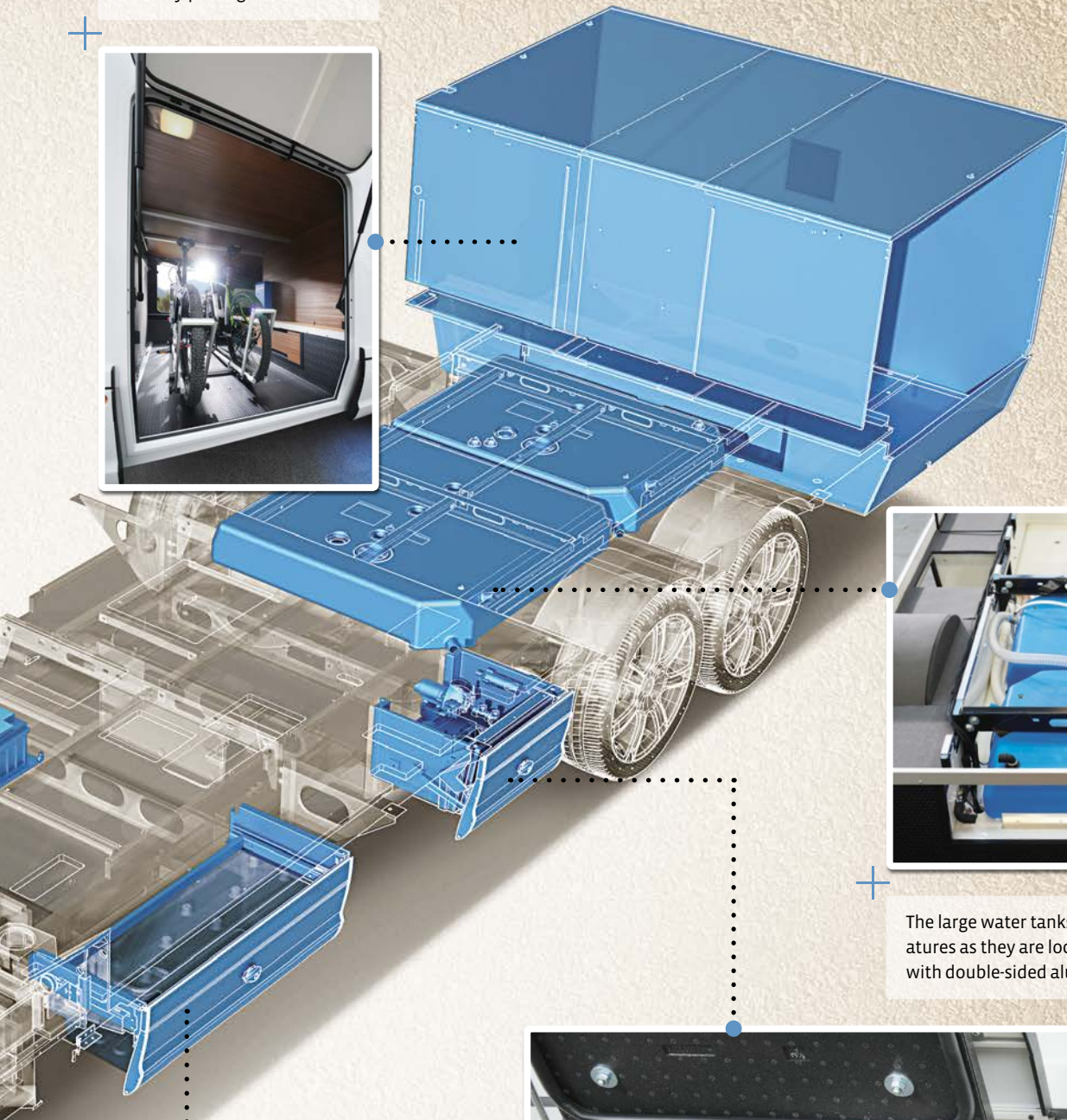

The large water tanks do not freeze even in sub-zero temperatures as they are located in the frost-proof floor, insulated with double-sided aluminium sandwich.



The large optional drawers behind the skirt panel are perfect for storing power cables, water hoses and tool kits.



The service flap is located on the left side, making it easier to pull up at service stations. This also prevents smells or staining from occurring on the sunny side of your motorhome.

A GIANT LEAP FOR WARM FEET.



You're always well prepared with an Arto, even for those colder days on your holiday or for your winter break. Whether you go for the standard Truma air heating or the optional warm-water heating from Alde, you can have a cosy holiday in your Arto, even in sub-zero temperatures outside, thanks to our sophisticated, holistic heating concept.

Holistic means that all three components – the optimal heating installation, the prevention of cold bridges and the optimal air circulation – come together to form a whole, with very simple benefits for you. Like warm feet.

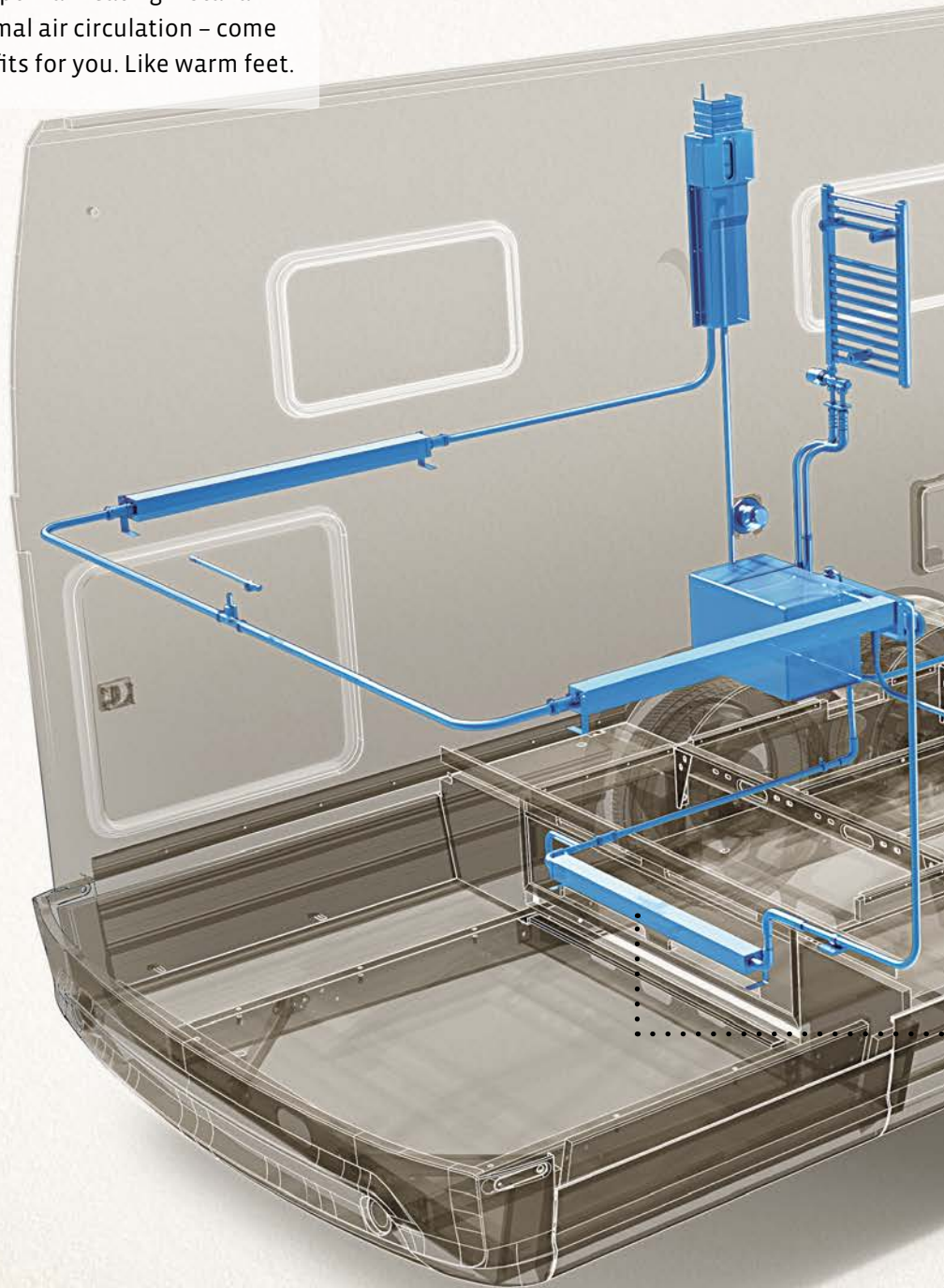
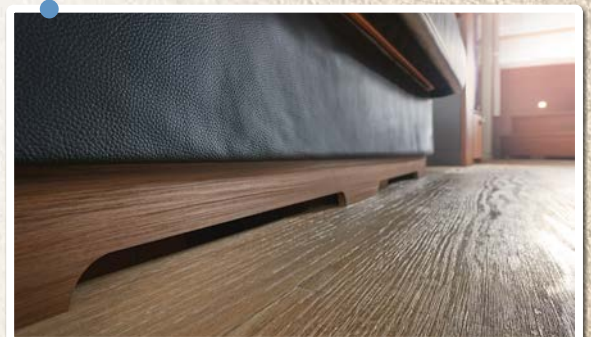
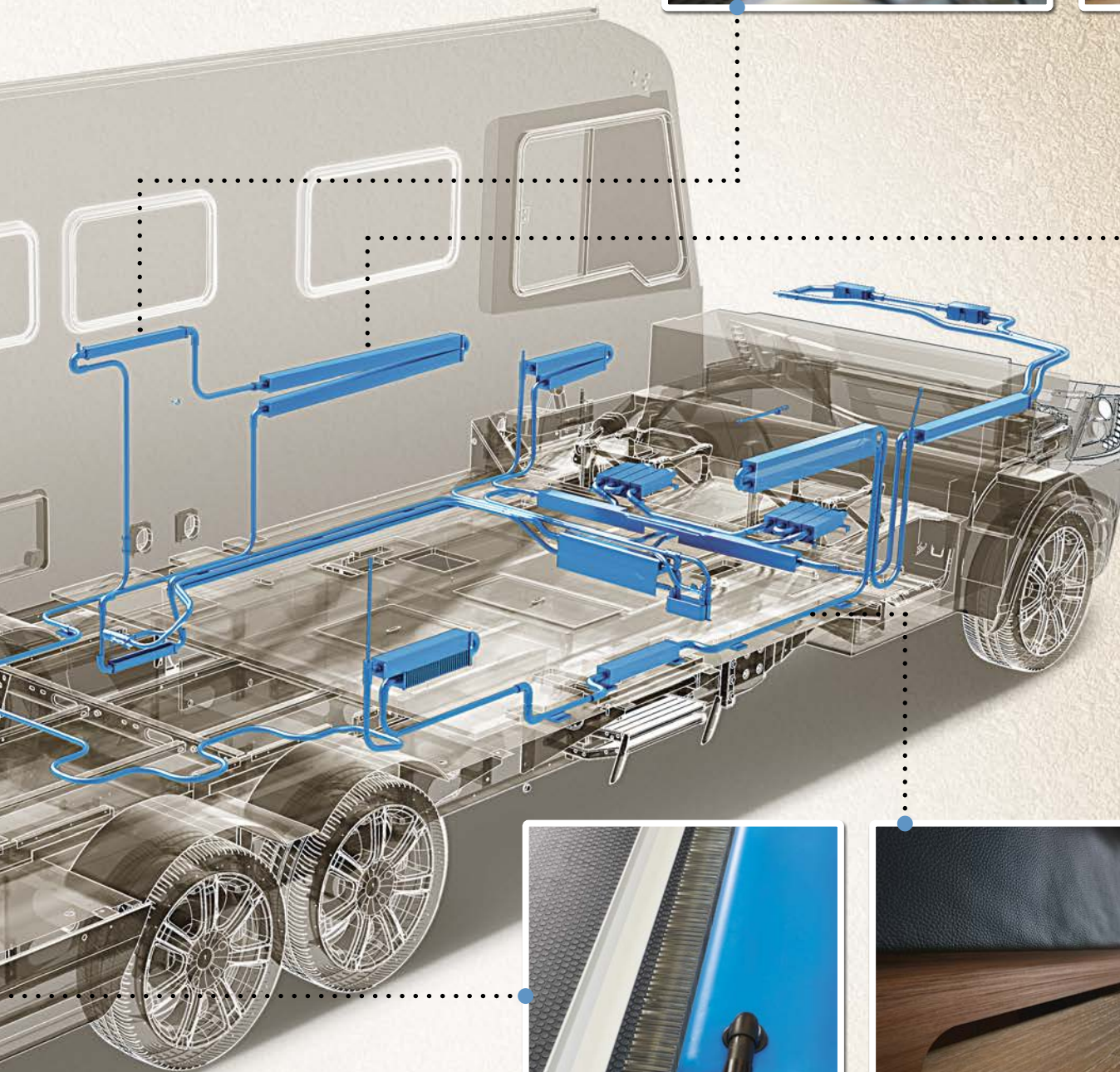

Illustration showing optional Alde 3020 hot water heating

Thanks to additional rear walls behind the cabinets and cushions, the air can also circulate behind the furniture and the heat from the heaters can disperse throughout the entire room.



Convector heaters in the floor protect all the fittings from cold weather. The double floor also serves as a heat storage and gives off heat to the floor similar to underfloor heating.

The warm air from the floor also gets into the circulation through small air vents in the seat benches. It comes up again behind the furniture and is dispersed evenly throughout the entire room. This prevents build-up of heat at individual places.

DOUBLE-SIDED ALUMINIUM. A GOOD IDEA, WHICH WE HAVE MADE BETTER.

Whether it's a summer or a winter holiday, you can always get caught cold by the weather. Or caught in a sweat. We have ensured that the temperature always feels just right on your holiday – at least in your Arto. We have been making panels from double-sided aluminium for more than 30 years and have been improving the material since the beginning. The structure is simple – aluminium on the outside, styrofoam on the inside. In this composition, the walls are virtually non-conductive – heat and cold have to stay outside. And so that you are insulated all around, we don't just use this material in the rear and side walls, but also in the floor and in the exterior storage doors. But despite all this insulation, we'll also keep our fingers crossed for good weather, of course.

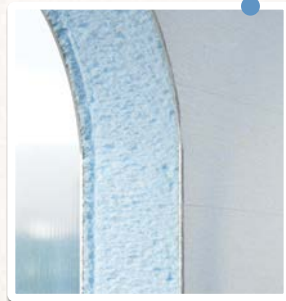

We use aluminium on the outside and styrofoam on the inside, based on the sandwich principle, so that the walls don't conduct either heat or cold.

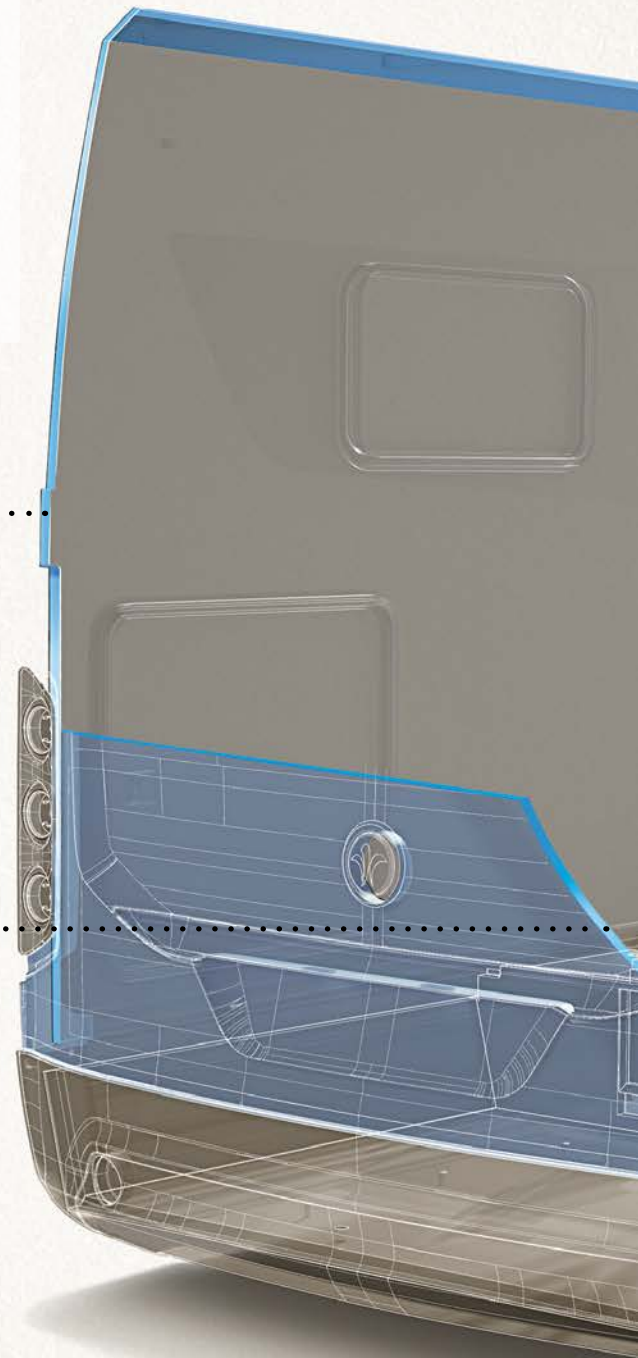

The connection between the roof and the side walls is also free of cold bridges thanks to double-sided aluminium.

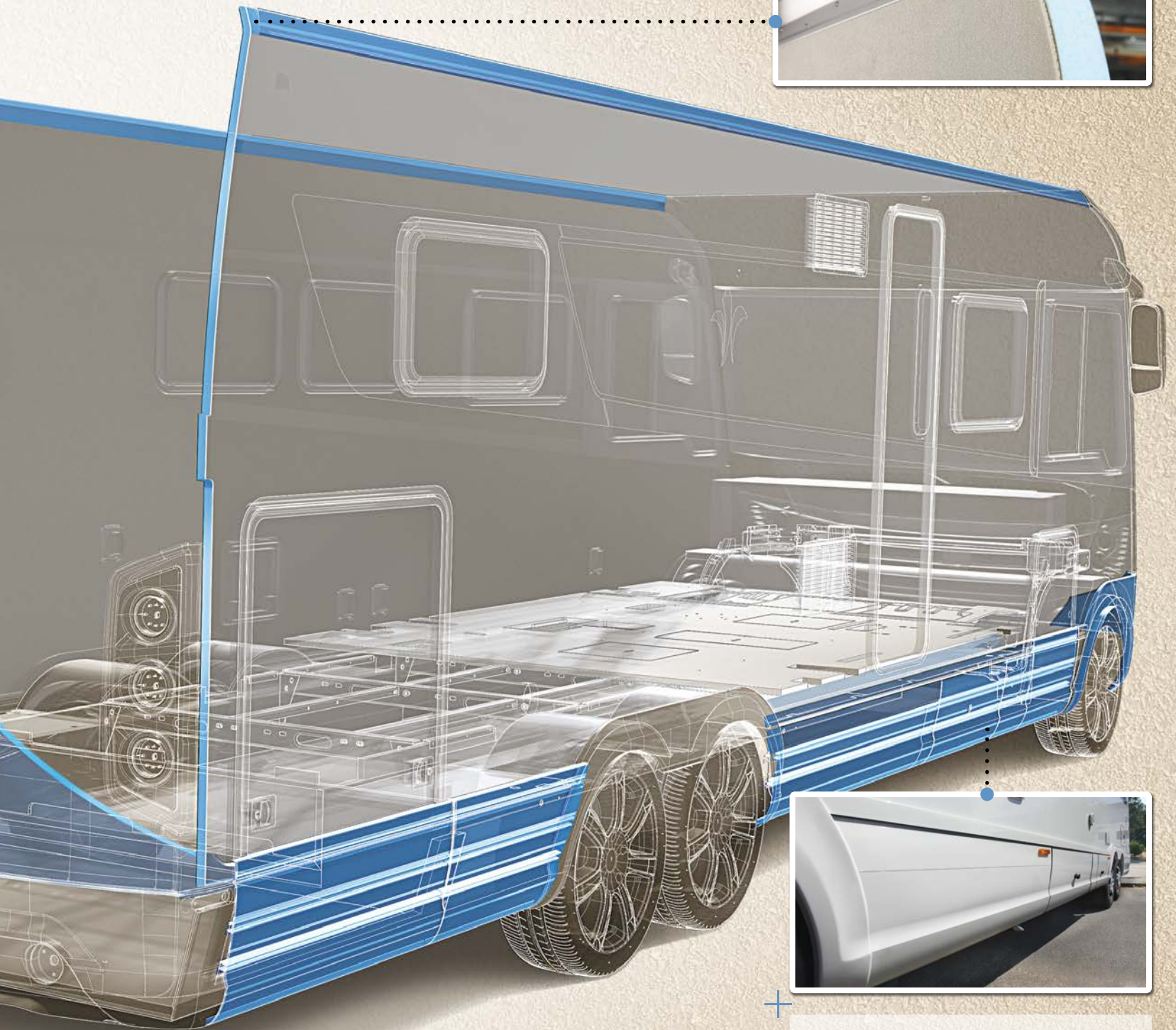
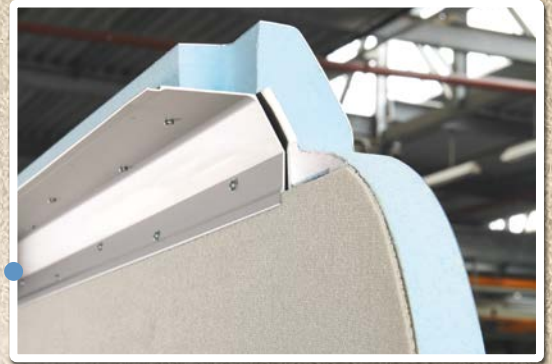

The elaborate side skirts made of varnished aluminium profiles give the Arto a sporty look on the outside. They cover the chassis frame and the retracted outside step.

STILL ONE OF THE WARMEST PLACES ON A WINTER HOLIDAY.

Only when it is really cold outside can you see for yourself that we have found a solution for a cosy, warm interior in our models, even in difficult places. If you tend to spend your holidays in colder places, we also offer you some extras that put an end to cold bridges and make your Niesmann+Bischoff a warm place that you always want to come home to.



We had to come up with something special for the large panoramic windscreen. They don't come in double glazing. The optional electrically operated and insulated front blind ensures that the cold stays outside, even here. The intervening space is also heated directly.



The rear ventilation on the windscreen works in conjunction with the convector heaters like a thermal screen.

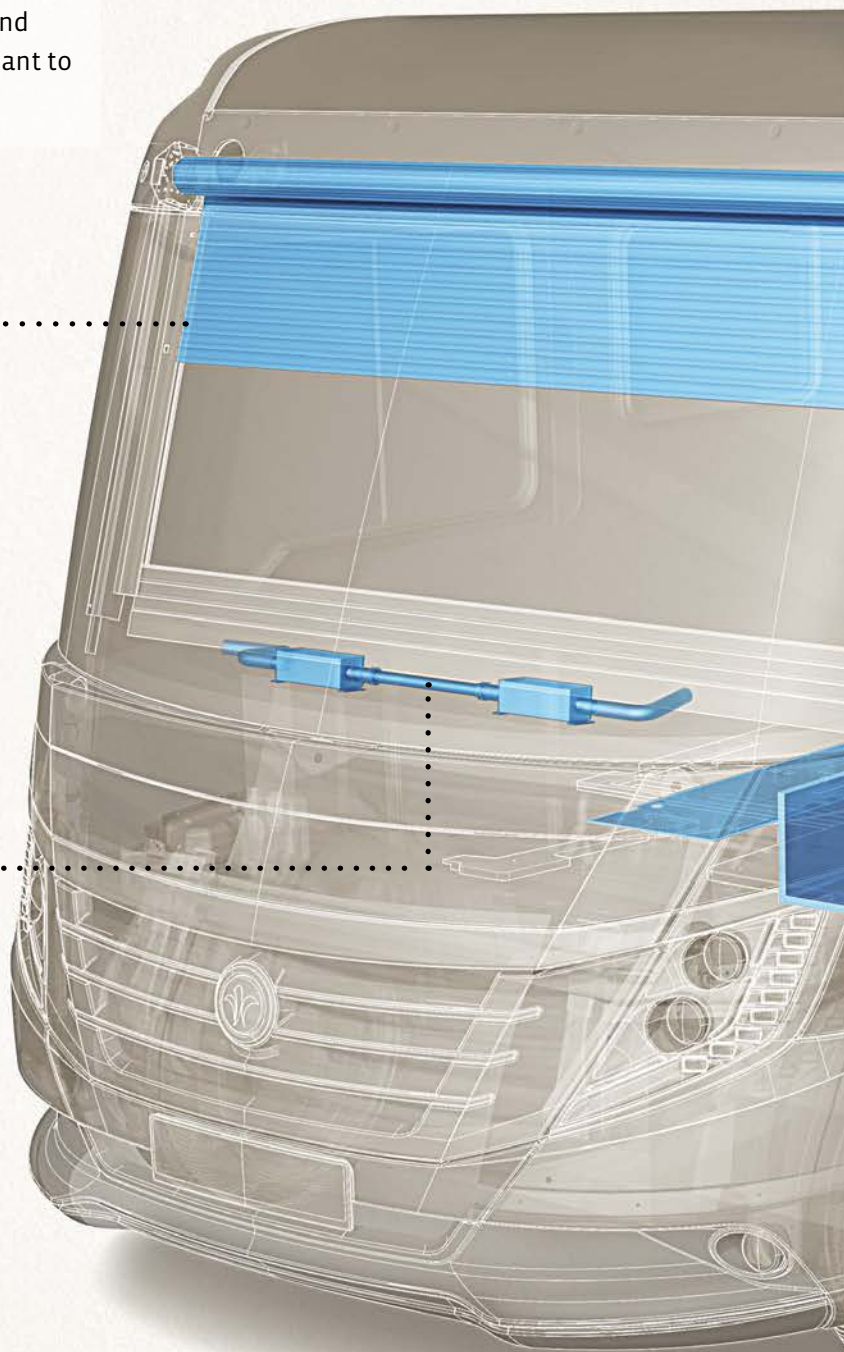

The optional Seitz S7 windows are double-glazed. They are easy to operate with one hand and have thermally broken aluminium outer frames.



The double-glazed side windows ensure better insulation and also offer up to 80% more heat protection than conventional, single-glazed side windows.

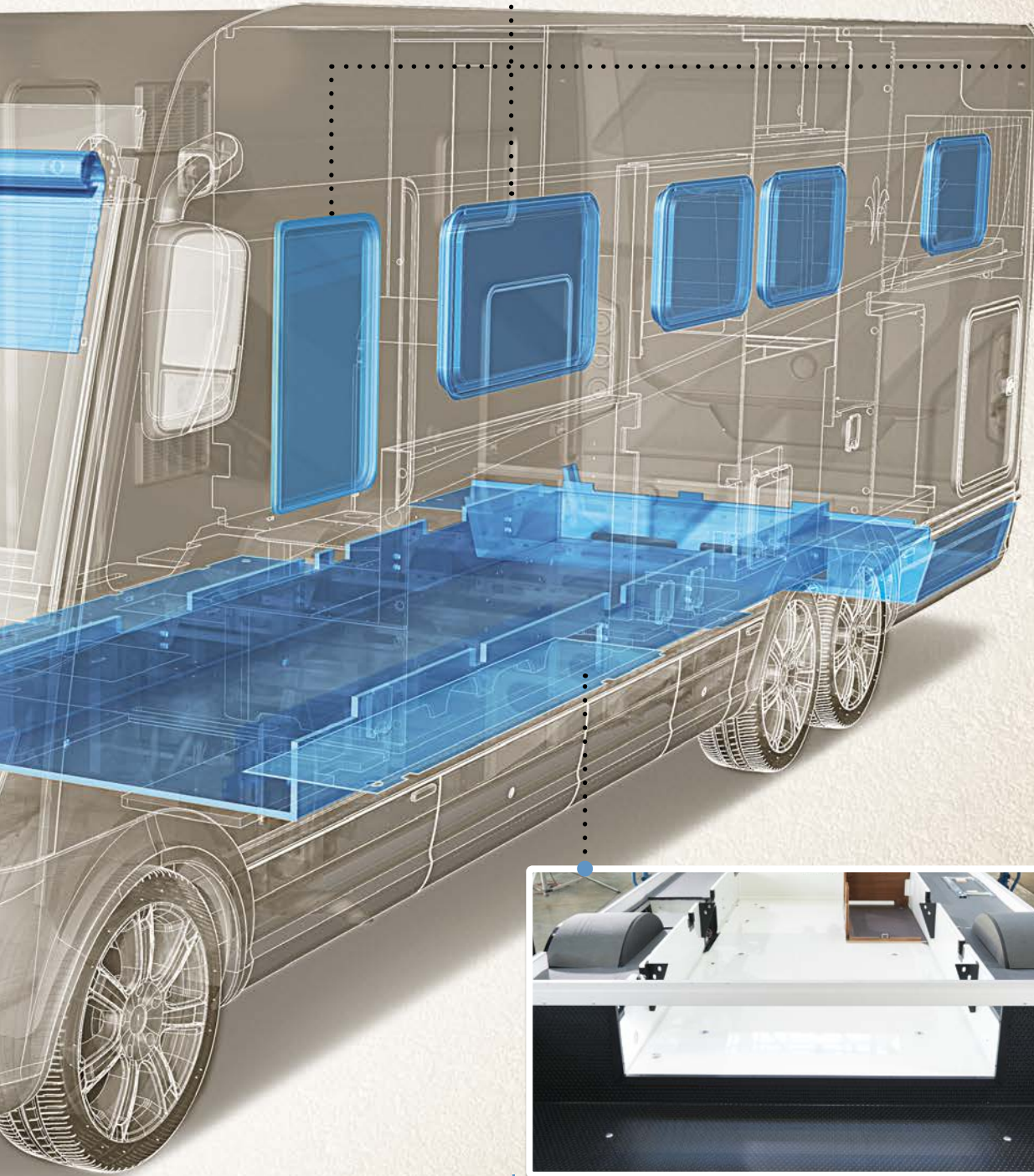
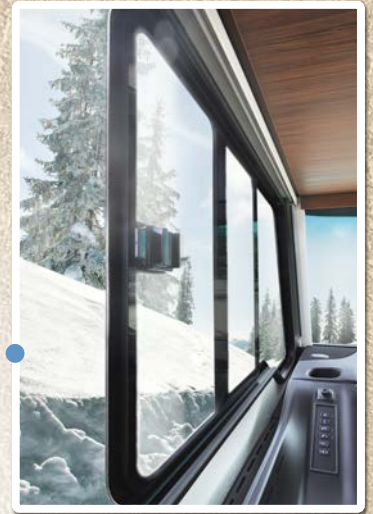

The floor also insulates the interior of the vehicle, as the lower floor is made entirely of double-sided aluminium sandwich.

THE HIGHEST QUALITY, PARTICULARLY ON THE ROOF.

Not everything that comes from above is good. Hail, branches, stone chips, incessant rain and occasionally even footballs – the roof of a motorhome has to deal with a lot of things. And we have done everything in our power to develop the perfect material for the roof of our motorhomes.. And the result: glass-reinforced plastic with extra-high glass content. The additional gelcoat finishing makes the roof extremely robust and scratch-proof without affecting its lightweight design style. In doing so, we have also greatly increased the flexural rigidity.



The flush-mounted transition from the front mask to the roof prevents back pressure of water and ensures that the water runs off to the front.

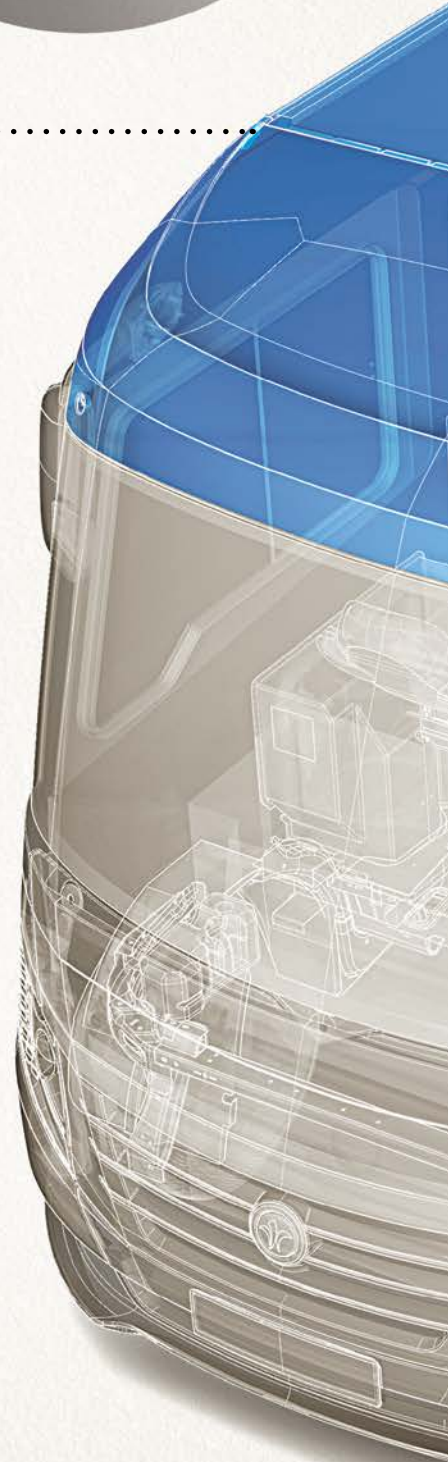

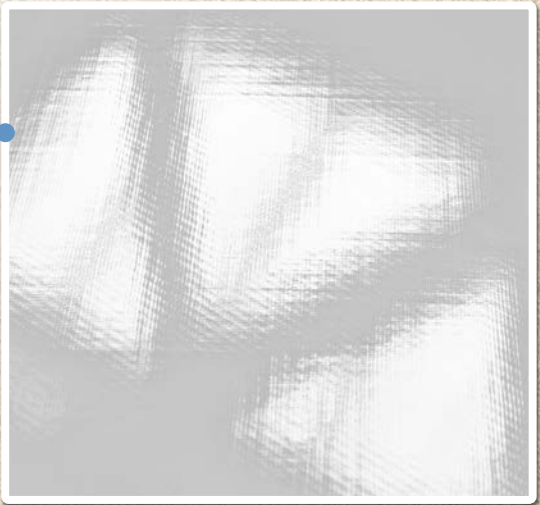
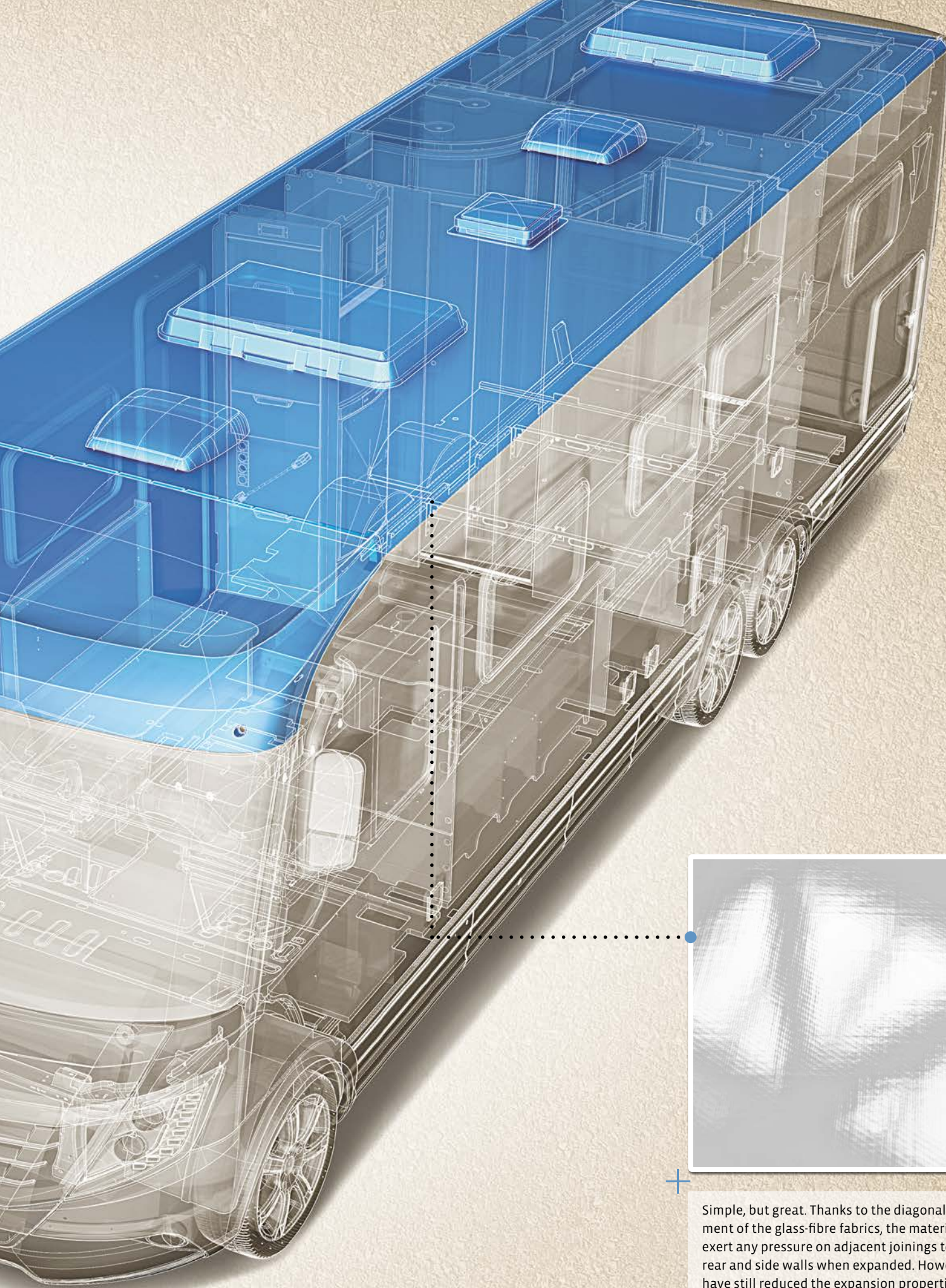

Simple, but great. Thanks to the diagonal arrangement of the glass-fibre fabrics, the material cannot exert any pressure on adjacent joinings to the front, rear and side walls when expanded. However, we have still reduced the expansion properties to a minimum in any case.

SEVEN

RATHER THAN THREE, + IN CASE YOU'RE NOT PAYING ATTENTION.

An Arto is big, but there's still no space for certain things – like dents at the front and rear, for example. So we put on our thinking caps and came up with a solution. Or rather seven solutions. This has a number of benefits. For one, some parts can be changed more cheaply than others; secondly, this enables quicker access to the cooler and engine bay.





We manufacture all parts from extremely wear- and scratch-resistant GRP. And the best thing of all about this material – small scratches can be polished away using gelcoat paste, while larger scratches are taken care of with a special surfacer.



YOUR FIRST TWO HOLIDAY DESTINATIONS: DRIVING PLEASURE AND SAFETY.

You and your new Arto will discover many new holiday destinations together, clocking up thousands of miles en route. We have invested a lot of time and engineering in your driving pleasure and safety, so your holiday can begin before you even hit the road. And if you'd like to reach your destination even more relaxed, a few little extras can make travelling in an Arto an even more comfortable experience.

Of course, we all like to look in front of us. But to make sure you reach your destination safely, it's important to look back regularly as well – using our large wing mirrors (Liner pack) with wide-angle field and few blind spots.



Thanks to the optional rear-view camera, you've got the best views of the concealed area behind the closed rear wall.



Body door with two-fold locking and electrical closing.

With the additional cross-bracing in the low frame, you can enjoy a fun driving experience with secure road-holding.



Your back will savour every mile it travels in our comfortable SKA seats (Liner pack). They adapt perfectly to the contours of your body. You can raise or lower the seat by 120 mm, for example, extend or even tilt it. But don't forget to take little breaks, too: simply turn both seats around 180 degrees, fix them in place, extend the back rest, then put your feet up on the sofa and close your eyes.



The LED daytime running lamps perfectly match the automotive design and guarantee optimum illumination of the road as well as perfect night vision.



Beautiful weather. But it's a good thing the standard gradient tint and the tinted windscreen mean that you don't need to squint your eyes while driving.



If the gradient tint is not enough, you can also darken the panoramic windscreen with the optional electrical front blind – but not so dark, of course, that you can't see the road in front.



THE BEAUTIFUL SIDES OF YOUR HOLIDAY.

Did you know that people fall in love quicker on holidays than at home? With our Arto comfort liner, it's often love at first sight. Its automotive design and sporty look with convex and concave shapes catch the eye right away. Its distinctive appearance has already impressed a number of expert panels and won several design awards – most recently, the Automotive Brand Contest and the Red Dot Design Award in 2014.

The new Niesmann+Bischoff face emphasises the width and dynamic nature of the vehicle – accentuated by the unique daylight blinker modules, the subtle chrome details and the brand logo placed at the front.



“Thrilling surfaces” – convex and concave muscles and edges create fascinating light effects and lend structure to the surfaces.



reddot award 2014
honourable mention



The visor unit is well proportioned and stretches the vehicle visually. A bold window line on the side ensures a clear structure.



Structures are channelled directly to the rear through the wheel area and sill. The connection between the front and rear is a key element in the vehicle's integrative design.



The rear is topped off by LED tail lights with the unique, threefold night signature and the perfectly integrated, dirt-proof rear-view camera (optional) set behind the logo.



At the rear, the chrome trim continues the subtle edges and muscular surface structure of the aerodynamic cut-off edge on the tail section.



OUR MOTORHOMES ARE READY TO TAKE TO THE ROAD AFTER THESE TESTS.

To guarantee the highest level of quality, we really need to know our stuff. After we have proceeded meticulously through each planning and production step, our first model, the prototype of an entire series, must come through a range of tests. Then, and only then, when it comes through all the tests with flying colours, do we start production of a model like the Arto. And we continue testing.





We sent the Arto to a very special test track. Here it met with very strong vibrations, so that after 100 laps, it had been subject to a stress equivalent to over 60,000 miles on the road. This allows us to identify any weak spots right away and fix them quickly.



TESTS, TESTS AND + MORE TESTS.

A holiday is full of surprises. Also when it comes to road surfaces, unfortunately. Thankfully, you're prepared for all manner of wilderness with an Arto. Before a vehicle leaves our factory, we put it to the test on our own test track where it comes face to face with sine waves, potholes, concrete waves and bumpy paving. The surfacing on our track is more extreme than in a natural environment, but if the Arto can come through here, it can come through anywhere.

And then we carry on testing. Next, it's time for each model to undergo the obligatory leak test. Not with regular water. We take common rainwater, which, thanks to its low surface tension, can really show up any leak. For this test, we collect extra rainwater in our own cistern.

After so much rain, it's time for some sun – because after all these tests, the Arto is finally ready to travel the world with you.



WE'VE REACHED THE FINISH LINE: NOW YOU CAN HIT THE ROAD.

Your Arto is ready! Finally, you can turn the ignition key and start it up. With the anticipation of an unforgettable holiday. With that new vehicle fragrance in your nose. With the certainty of always arriving safely. With the feeling of driving a car. With the freedom of taking a break whenever you like and turning the driver's seat into a recliner. With the assurance that you can get a good night's sleep anywhere. With the luxury of a shower like in your own home. With the tranquillity you feel after spending a little time on your own. And with the possibility that tomorrow you might just discover the most beautiful place in the world. With the best ideas for your holiday.







IMPRINT

Subject to errors and changes. After the editorial deadline (07/2014), there may be changes to the models, products, plans, technical information, features, illustrations, etc. The illustrations also contain special features and/or accessories which are not part of the standard features or decorations in the Niesmann+Bischoff product range. Illustrations may be inaccurately depicted due to graphical conversion, image editing or technical production factors.

PUBLISHER

Niesmann+Bischoff GmbH
Clou-Str. 1 | 56751 Polch | Germany
T +49 2654 933-0
F +49 2654 933-100
M info@niesmann-bischoff.com
W niesmann-bischoff.com

CONCEPT AND DESIGN

BUTTER. GmbH

PHOTOGRAPHY

mooi - STARKE FOTOGRAFIE

TECH. PRESENTATION + RENDERINGS

Studio SYN

PRINTING

Druckstudio GmbH

ARTO/ CATALOGUES MODELS 2015/
GB (V07/2014)

NIESMANN-BISCHOFF.COM