

**NIESMANN
+ BISCHOFF**

FLAIR



Clou inside

GB



CONTENTS

04	ON THE ROAD WITH THE FLAIR
28	CLOU: THE STAR ATTRACTION
30	A LOOK INSIDE THE FLAIR

JOIN US ON A VOYAGE OF
DISCOVERY.







YOU'RE TRAVELLING WITH A FLAIR⁺ IF YOU'RE
BROADENING
YOUR HORIZONS
WITH EVERY NEW DAY.

Just when you think you've seen everything there is to see, you turn a corner and discover something new. For us, this is what real travelling is about. We want to keep surprising our customers with great innovations and are constantly working to improve our Flair luxury liner. This year, we've come up with an automotive design that you're bound not to have ever seen before.



NIEMANN + BISCHOFF

MY NB 20









YOU'RE TRAVELLING WITH A FLAIR IF
YOU DON'T BRING YOUR
PRIZE CATCH
HOME, BUT RATHER THE OTHER
WAY AROUND.

Dining out is simply part of being on holiday. With a Flair, this is a natural part of the experience. Just like in the world's best kitchens, you've got the freshest ingredients on hand, and all directly from natural sources. On robust worktops, you can conjure up a mouth-watering menu. And for a little variety, just drive on and dine in a new location tomorrow.

YOU'RE TRAVELLING WITH A FLAIR ⁺ IF 1.9 M² IS
ALL IT TAKES TO SHOW OFF YOUR
GREAT CULINARY
SKILLS.

Fine dining doesn't always have to come from France. Our kitchen, for instance, is made in Germany and combines top quality with an intelligent use of space. Here you can even prepare the finest French cuisine.







The image shows the interior of a motorhome. In the foreground, a dining table is set with a bottle of wine, a glass of red wine, a plate of cheese and bread, and a plate of vegetables. The table is covered with a woven placemat. Behind the table is a long, upholstered bench seat with a striped pattern. Large windows on the right side of the motorhome offer a view of a lake and mountains under a bright sky. The interior has wood paneling and overhead storage cabinets.

YOU'RE TRAVELLING WITH A FLAIR + IF EVERY MOMENT
OF YOUR HOLIDAY MAKES YOU
HUNGRY FOR MORE.

Today, we'll dine either in the spacious interior or outdoors in the middle of nature. And tomorrow we'll dine out again, or perhaps in a new place. With a Flair, you can enjoy your freedom to the full. Everywhere, every day, at every moment.

YOU'RE TRAVELLING WITH A FLAIR⁺ IF YOU'RE
STILL RELAXED,
NO MATTER HOW THRILLING YOUR
DAY HAS BEEN.

The best moments in life are usually not planned. But sometimes they are just the way you imagined. So indulge in the luxury of simply switching off so you can enjoy these moments in the here and now. Because in a Flair, you're always on holiday – wherever you are on the road.







A large, dark tree trunk stands on the left side of a road, with its branches spreading out. The scene is bathed in the warm, golden light of a sunset or sunrise, with the sun low on the horizon to the left, creating a strong lens flare and illuminating the foliage. The road surface is visible in the foreground, and the background shows more trees and a hazy sky.

YOU'RE TRAVELLING WITH A FLAIR ⁺ IF THOUSANDS
OF MILES PRODUCE UNLIMITED
HOLIDAY MEMORIES.

Our insider holiday tip: look less at your map and more out the window. It really doesn't matter if you get lost. Because in a Flair, you have already reached your destination long before you arrive.





YOU'RE TRAVELLING WITH A FLAIR ⁺ IF THE
CHIRPING OF CRICKETS
IS THE MOST PEACEFUL SOUND
YOU CAN IMAGINE.

Nothing beats a parking spot with a sea view. Except perhaps a parking spot beside old olive trees. Or by a lapping stream, while the sound of cowbells gently fills the air. Our favourite places are all different, but they have one thing in common – we remember them with all of our senses. And if we should feel a sense of longing, we can happily return there any time with a Flair. Or simply discover a new favourite place.

The image shows the interior of a motorhome. In the foreground, there is a large, textured green cushion on a black leather seat. To the right, a woman with long blonde hair, wearing a pink top, is seen from behind, looking at a television mounted on a wooden cabinet. The TV displays a scenic view of a beach and mountains. Large windows on the left side of the motorhome offer a view of a landscape with palm trees and hills under a bright sky. The interior features wood paneling and modern lighting fixtures.

YOU'RE TRAVELLING WITH A FLAIR + IF YOU CAN
ENJOY YOUR FREEDOM
EVEN WHILE STAYING INDOORS.

When you travel with a Flair, you see the world and discover many new things. But sometimes you don't need to go very far to see something different - thanks to the replaceable cushion covers in the interior.





The image shows the interior of a motorhome. On the left, there is a bed with white pillows and a blue and white striped blanket. A wooden door is in the center. To the right, there is a window with white curtains, and a bottle of wine and a glass are on a small table in front of it. The ceiling has a recessed light and a speaker. The overall atmosphere is cozy and comfortable.

YOU'RE TRAVELLING WITH A FLAIR IF YOU SPEND YOUR
WHOLE HOLIDAY
TRAVELLING JUST TO ARRIVE
BACK HERE.

At the beach or in the mountains – fresh air makes you tired. Or maybe it was the glass of wine you enjoyed in the snug sitting area in the corner? Now it's just a couple of steps to the comfortable bed in the separate sleeping area.



YOU'RE TRAVELLING WITH A FLAIR⁺ IF YOU CAN
SLEEP JUST AS WELL
ON STONES.

With a Flair, you are finally one of those enviable people who can sleep well anywhere. In the city or in the mountains, power napping in front of the television, or through the night in the bedroom. Just draw the curtains, pull down the blinds and put everything out of your mind. Good night and good morning!





CLOU:

THE STAR ATTRACTION.

More than 30 years ago, we at Niesmann+Bischoff launched our first motorhome on the market. We called it Clou, as though we already had a clue of what was to come. As a motorhome, it was unprecedented on the market. The Clou was filled with ideas still unique at the time and which quickly led to imitations. With its special solutions that caused a sensation, it won many fans in the industry.

Nothing has changed. Day by day, and model by model, we are looking for new solutions that make travelling in a liner an unforgettable experience. We live by these ideas, they show us the way and they make all the difference. They are simply the Clou – ideas no else has even considered before. Our Clou will delight you on every trip you take with a Niesmann+Bischoff, whether you choose to hit the road in a Flair or an Arto. Both are star attractions: both have the Clou inside.



Clou inside

THERE IS ALWAYS SPACE FOR GREAT IDEAS.

We're architects. Over an area of approximately 20 to 22 square metres, we have made you an entire home, with a cosy living room, a large bathroom, a kitchen that has everything you need and a bedroom made with the fabric of dreams. For this, we need to call on many great solutions. We invite you to our world of ideas, to a journey together through the interior of your new Flair.

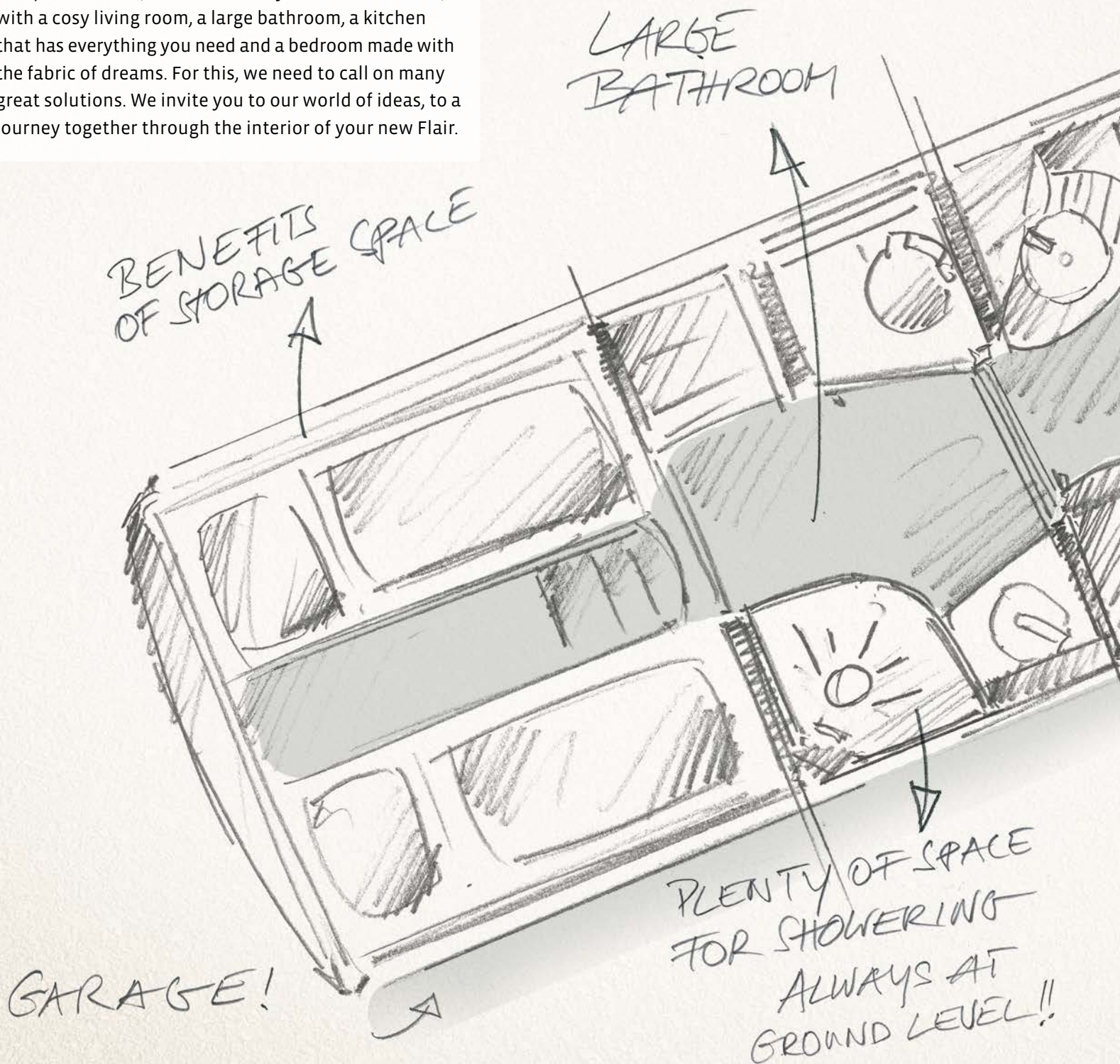

FULL
FITTED
KITCHEN

ROTATING
SEATS

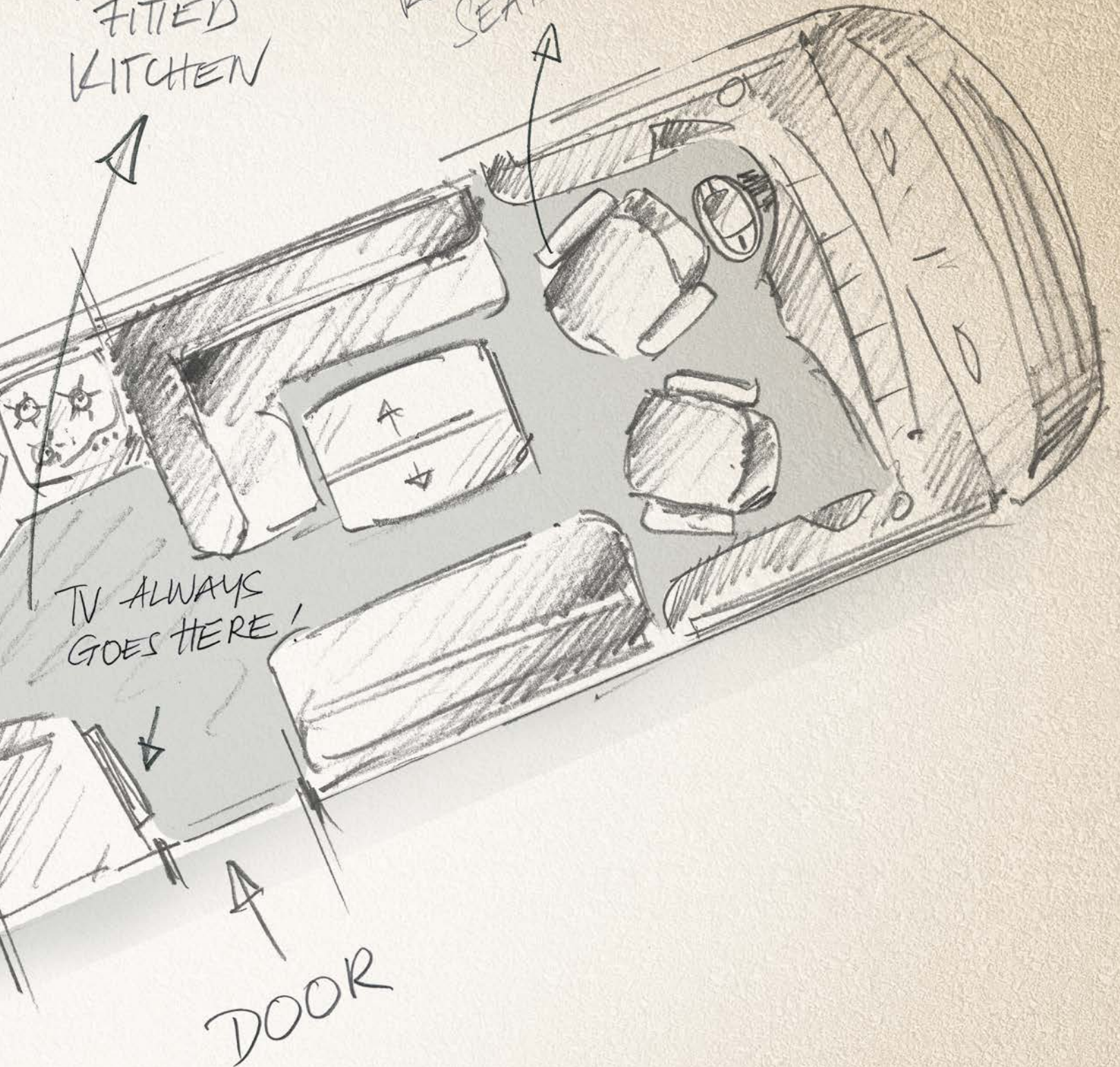

TV ALWAYS
GOES HERE!

DOOR



TRAVELLING MEANS FREEDOM. + IN THE INTERIOR, TOO.

Travelling with a Flair means freedom. And this freedom begins on the inside. When you're relaxing in your Flair and enjoying the view, it shouldn't end at the first partition wall before the kitchen. Thanks to our idea of retractable belt supports, it doesn't have to. This allows us to remove this wall completely and create a totally different sense of space. Now you can enjoy the luxury of unlimited freedom in each of our liners. Sometimes things need to be left out to achieve maximum comfort, whatever the cost.





120

MM

HEIGHT-ADJUSTABLE



180°

ROTATING SEATS

HOW A DRIVER'S SEAT BECOMES A RECLINER.

What's the difference between two comfortable, ergonomic driver's and passenger seats and two cosy recliners? Exactly 180 degrees, as the optional SKA seats in a Niesmann+Bischoff can be whichever you want. As driver's seats, they offer you support on long journeys and can be adjusted for the specific needs of every part of your body.

And when you feel the need to take a break and recharge your batteries, just spin the seat 180 degrees around until it locks in place, and adjust the height so you can rest your legs on the sofa in front of you. Now just fold your arms behind your head and enjoy a relaxing evening in front of the television.



ca. **19**

SQUARE METRES

THE MOST IMPORTANT INGREDIENTS IN OUR KITCHEN? GOOD IDEAS.

If you want to fit in an oven, fridge, freezer, one sink, three gas hobs, as many drawers as possible and even more, all within an area of just two square metres, you need to draw on a wealth of excellent ideas. At Niesmann+Bischoff, we have them in abundance. Everything is there, so you've got all you need, even on your holiday. The kitchen still manages to look spacious, as every detail has its own individual place. And to keep it this way, you can lock up and secure all the cabinets in the kitchen of a Flair with using a single switch.







WE DON'T HAVE ROOM FOR SMALL BATHROOMS.

With an array of ideas both large and small, we at Niesmann+Bischoff have ensured that you can enjoy an exceptionally large bathroom area with ample freedom of movement in each of our motorhomes. Enjoy the luxury of well-being within your own four walls with the added benefit that these walls are all particularly far apart.

THE WELLNESS SHOWER WITH RAIN GUARANTEE.

In the roomy bathroom of the Flair, there's always lots of space for a large shower. Because after a long, relaxing lie in the sun, there's no better feeling on holiday than stepping into the large and luxurious shower in a Niesmann+Bischoff. With the additional hand shower and high-quality, sturdy fittings, you've got everything you need for your well-being on holiday.

11,3
ca.

LITER/MINUTE

The high-quality pressure pump operates very quietly and evenly at a constant water pressure. You can only enjoy such a comfortable shower at home or in a Niesmann+Bischoff.



The only way to achieve an even greater sense of well-being in a Flair is with the star attraction in the bathroom – the rain shower.





OTHERS CAN ONLY DREAM OF THIS MUCH STORAGE SPACE.



We have found space where others have not even thought of looking. The bedroom in a Niesmann+Bischoff has all you need for a restful night and a sound sleep on an exceptional bed system.

THE BEST MATERIAL FOR YOUR HOLIDAY ADVENTURES.

We keep developing new ideas to make our vehicles even better. But sometimes we return to old inspiration – we only use the very best materials for our furnishings.



Scratch-proof 3D leaf lends a high-quality wooden look to the furniture and cabinets.



The sturdy door with high-quality fittings separates the bedroom and bathroom from the living area. As all the fittings and hinges in the Flair are made of metal, they will close securely and never wear.



We only use robust glass-reinforced plastic for the shower tray, so it is extremely wear and scratch-resistant.

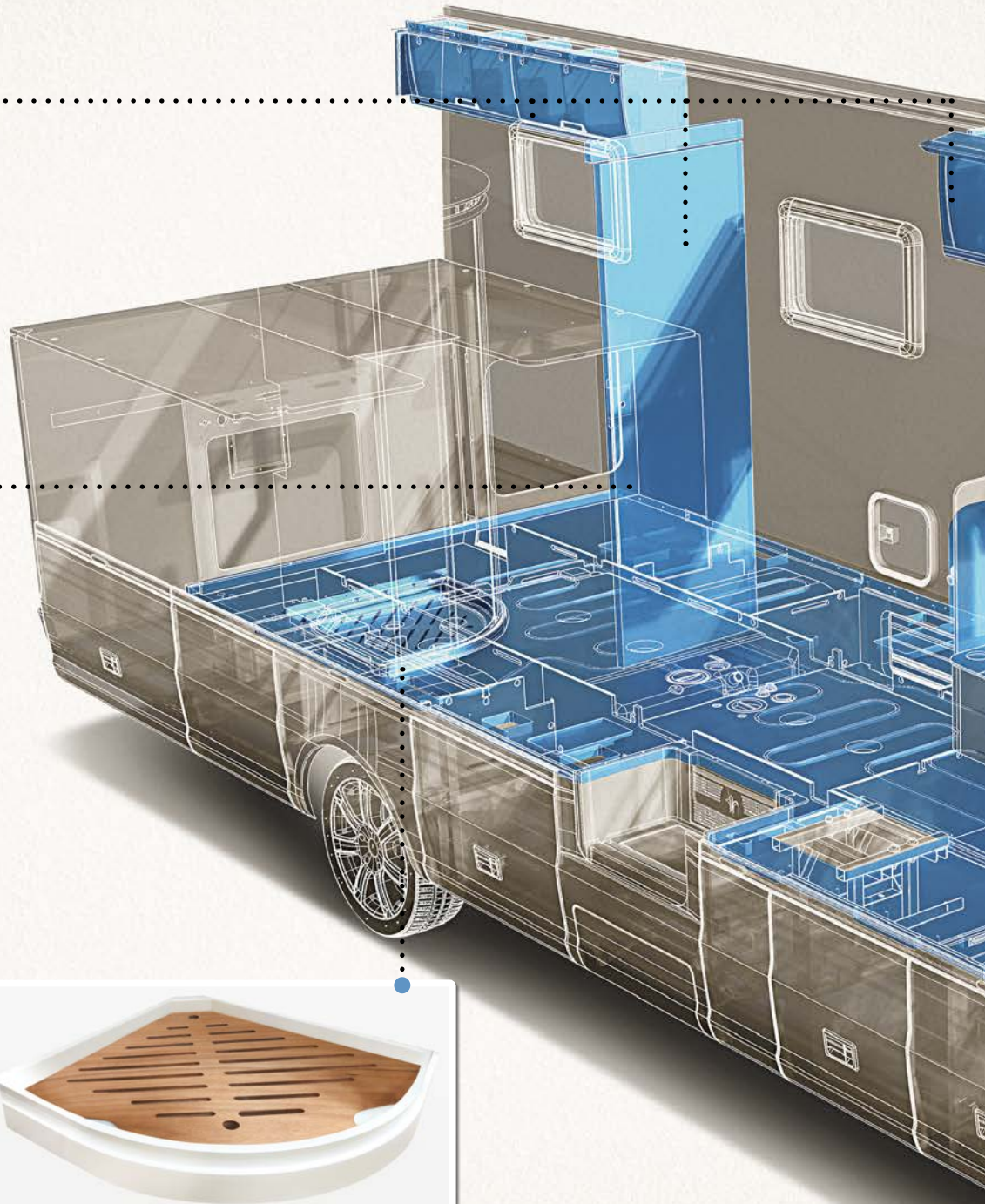

Thanks to our push-to-open latches, we can manage without knobs on many doors, as these can loosen through frequent pulling and pushing. With the latest hydraulic lifting technology, the upper cabinets open and close quietly and conveniently.



50,000

ABRASION CYCLES



The three-layer foam concept ensures sitting on the sofa is always comfortable; 50,000 abrasion cycles testify to the long lifespan of the covers. A gap in the upholstery ensures convenient access to the storage space underneath.



The floor is particularly robust thanks to its vinyl coating with wooden look and structure.

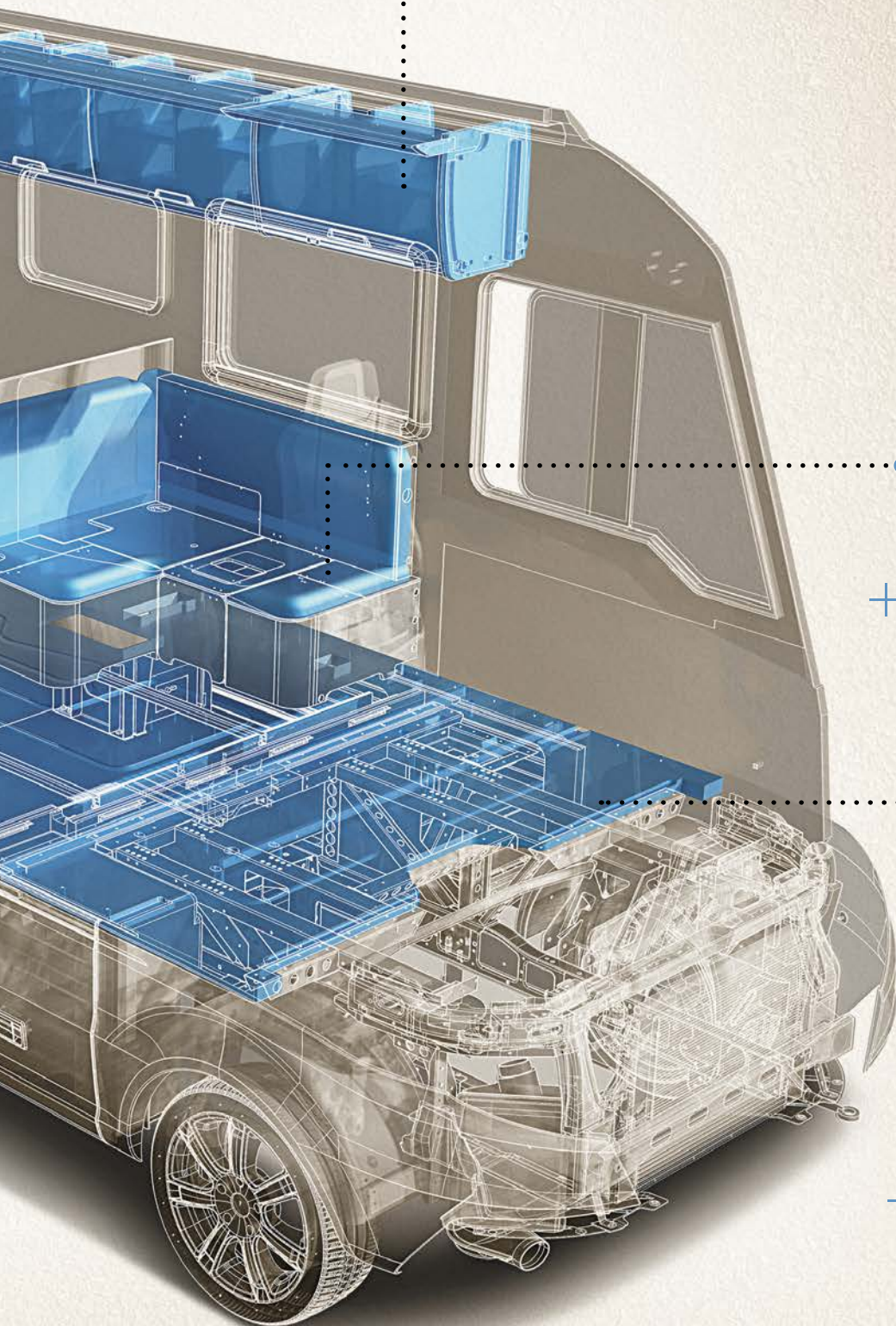

The image shows the interior of a motorhome. A white sofa with several pillows is in the foreground. The pillows have a hand-drawn sketch pattern and the text "CHANGE THEM WHENEVER YOU LIKE!". In the background, there is a wooden cabinet with a television, drawers, and a door. Large windows on the left side offer a view of a lake and hills. The ceiling has recessed lighting and a storage compartment.

CHANGE THEM
WHENEVER YOU LIKE!

WE GIVE YOU COMPLETE FREEDOM.
INCLUDING THE FREEDOM TO MAKE
YOUR OWN DESIGNS.

+

When it comes to interior design, there is no one perfect solution. There are more than 500 to be precise, and each is correct. We give you complete freedom to make your own designs. It's up to you now. Design your Flair just how you imagine a cosy home on the road should be. From more than 500 combinations, choose the one that suits you best. Scan the QR code to see some suggestions.



OVER
500

POSSIBILITIES

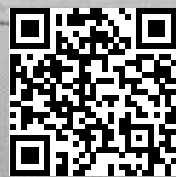







JUST LIKE THIS OR COMPLETELY DIFFERENT.

You've made your decision. You've found the perfect combination for you. At Niesmann+Bischoff, you can have even more. Even greater freedom. You can change the doors on the ceiling cupboards and the cushions in a snap. Swap them for your favourite combination or for that other one that you may like even more. With us, you can change your mind again and again.

CAN BE REPLACED
QUICKLY
AND SIMPLY.



RELAXING WITH STATE-OF-THE-ART TECHNOLOGY.

+

So we don't bore you with technical details over the following pages, we have simply fitted our Flair with as many interesting technological highlights as possible. And of course to offer you maximum security and comfort on your travels. Over the following pages, take a peek at what's going on behind the scenes of our comfort liner while you're enjoying your holiday.





Optimum axle load is given as the weight of the installations is distributed across the double floor just so; the two large water tanks, for example, are located in the centre of the rear axle.

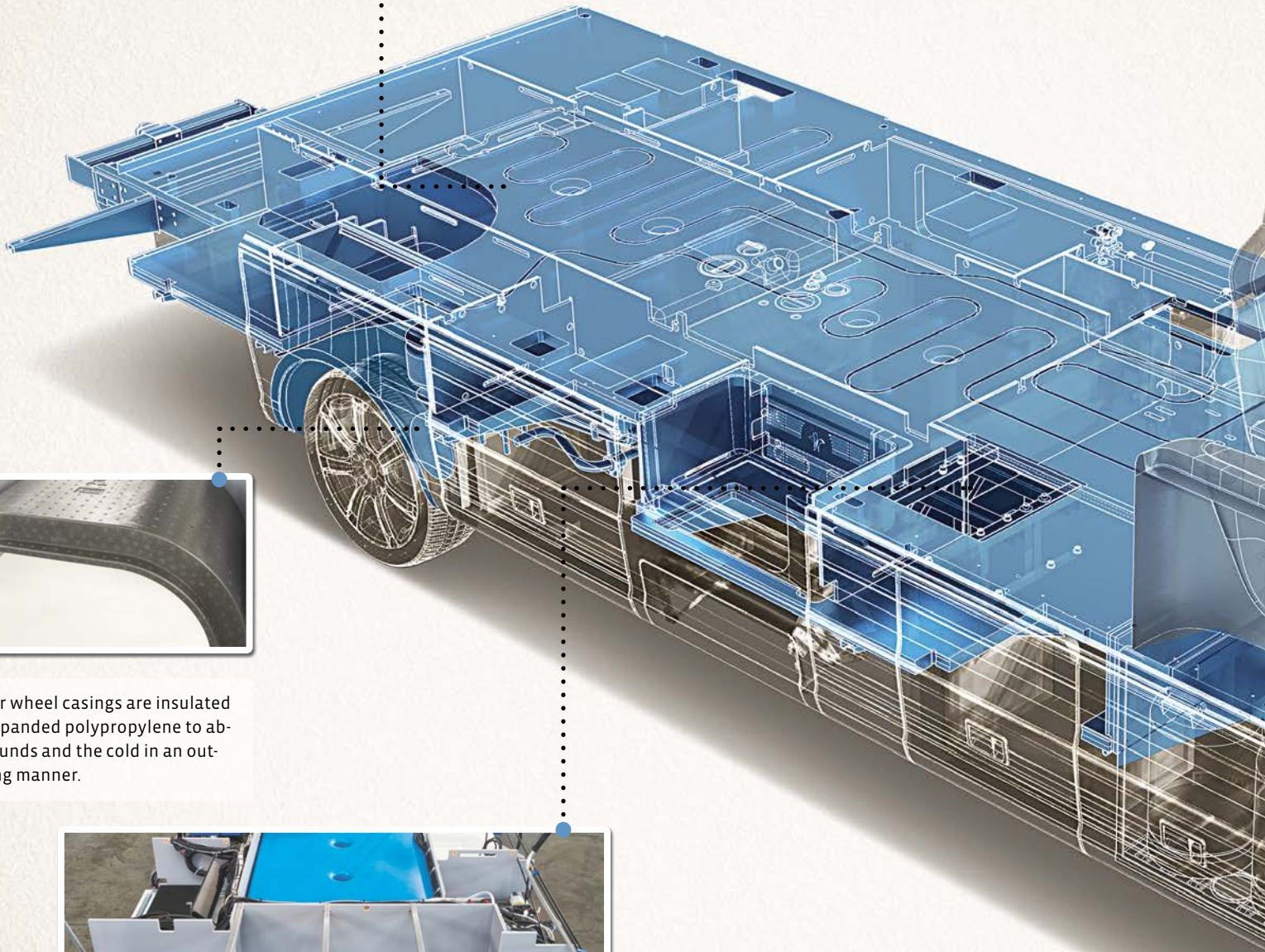

The rear wheel casings are insulated with expanded polypropylene to absorb sounds and the cold in an outstanding manner.

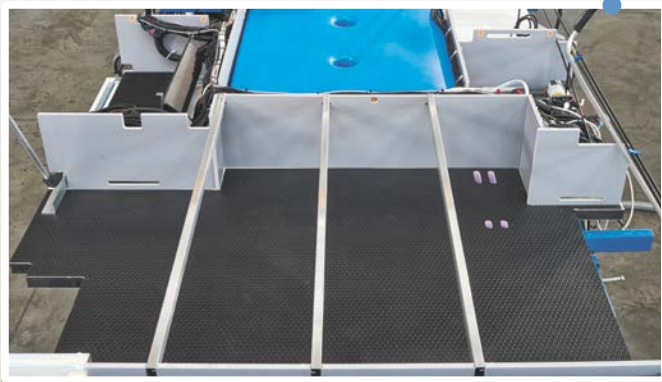

The combination of subfloor and floor panel ensure high rigidity of the chassis and, as a result, excellent driving qualities. What's more, the insulation afforded by the double-sided aluminium sandwich minimises road noise in the box construction.

TRAVEL WITH THE FEELING OF DRIVING A CAR.



We want your holiday to begin before you even hit the road. This is why Niesmann+Bischoff luxury liners offer unique driveability. We have done everything in our power to ensure that the Flair drives better than a vehicle the size of a motorhome.

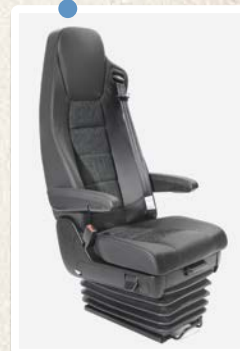
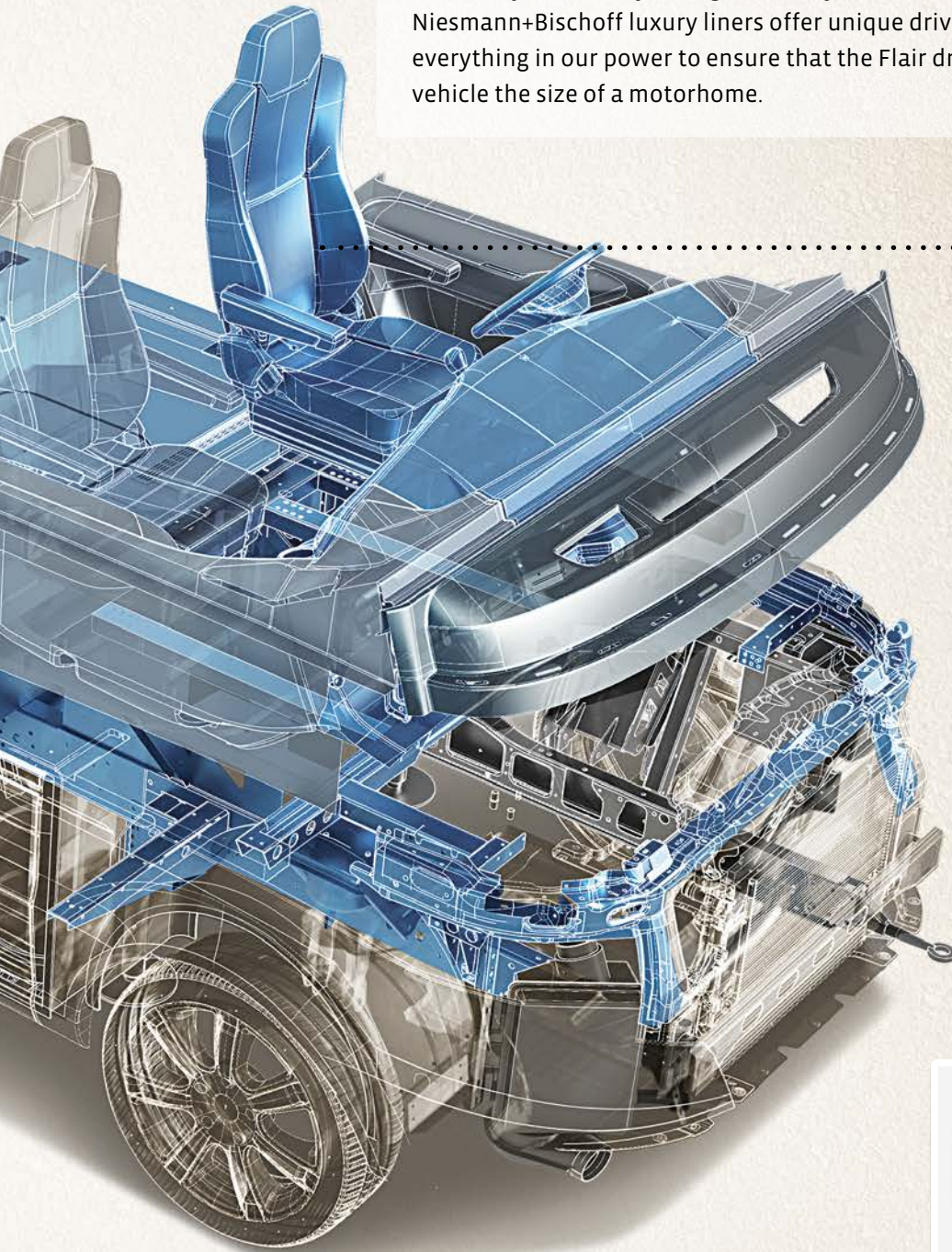

Enjoy exceptional ergonomics in the cockpit of the Flair, especially on longer journeys. Thanks to the sophisticated interplay between driver's seat, original IVECO instrument panel and steering wheel, you'll have the optimal seat position in no time at all.

WHEN IT COMES TO SERVICE, YOU'VE COME TO THE RIGHT PLACE WITH US.

Our motorhomes are extremely easy to service. Gas bottles, water tanks, batteries and service flaps for grey water and electricity are always in just the right place. Just where you need them.

The spacious gas bottle box offers ample space for two gas bottles of up to 14 kg (even with collars).

The spacious underfloor storage area can be accessed from both sides and makes optimal use of the available space.

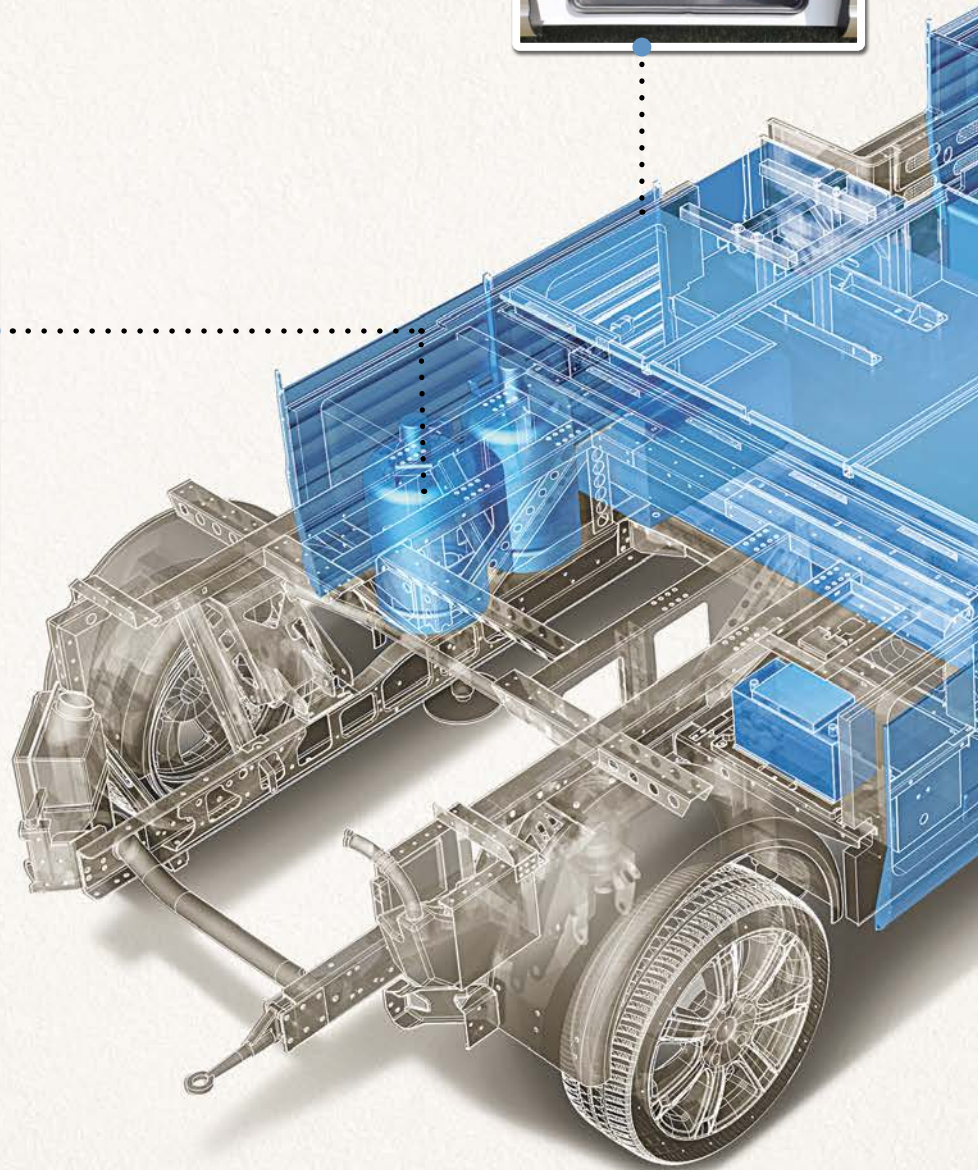
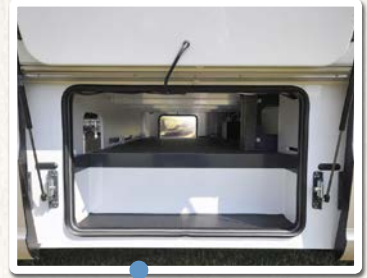
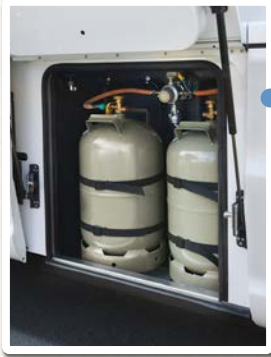

The spacious rear garage is 1.37 m high. It offers space for scooters, e-bikes or bulky packages. The entire onboard electronics are easily accessible through the garage.



The large water tanks are mounted in the heated double floor insulated with a double-sided aluminium sandwich and so won't freeze at sub-zero temperatures. The water tanks can be removed and replaced via the rear garage.



All installations and storage areas in the double floor can be accessed conveniently and in a way that's conducive to service – via the fully insulated bus flaps.



The service flap is located on the left side, making it easier to pull up at service stations. This also prevents smells or staining from occurring on the sunny side of your motorhome.

A GIANT LEAP FOR WARM FEET.



You're always well prepared with a Flair, even for those colder days on your holiday or for your winter break. With the standard warm-water heating from Alde and our sophisticated, holistic heating concept, you can have a cosy holiday in your Flair, even in sub-zero temperatures outside. Holistic means that all three components – the optimal heating installation, the prevention of cold bridges and the optimal air circulation, come together to form a whole, which has very simple benefits for you. Like warm feet.

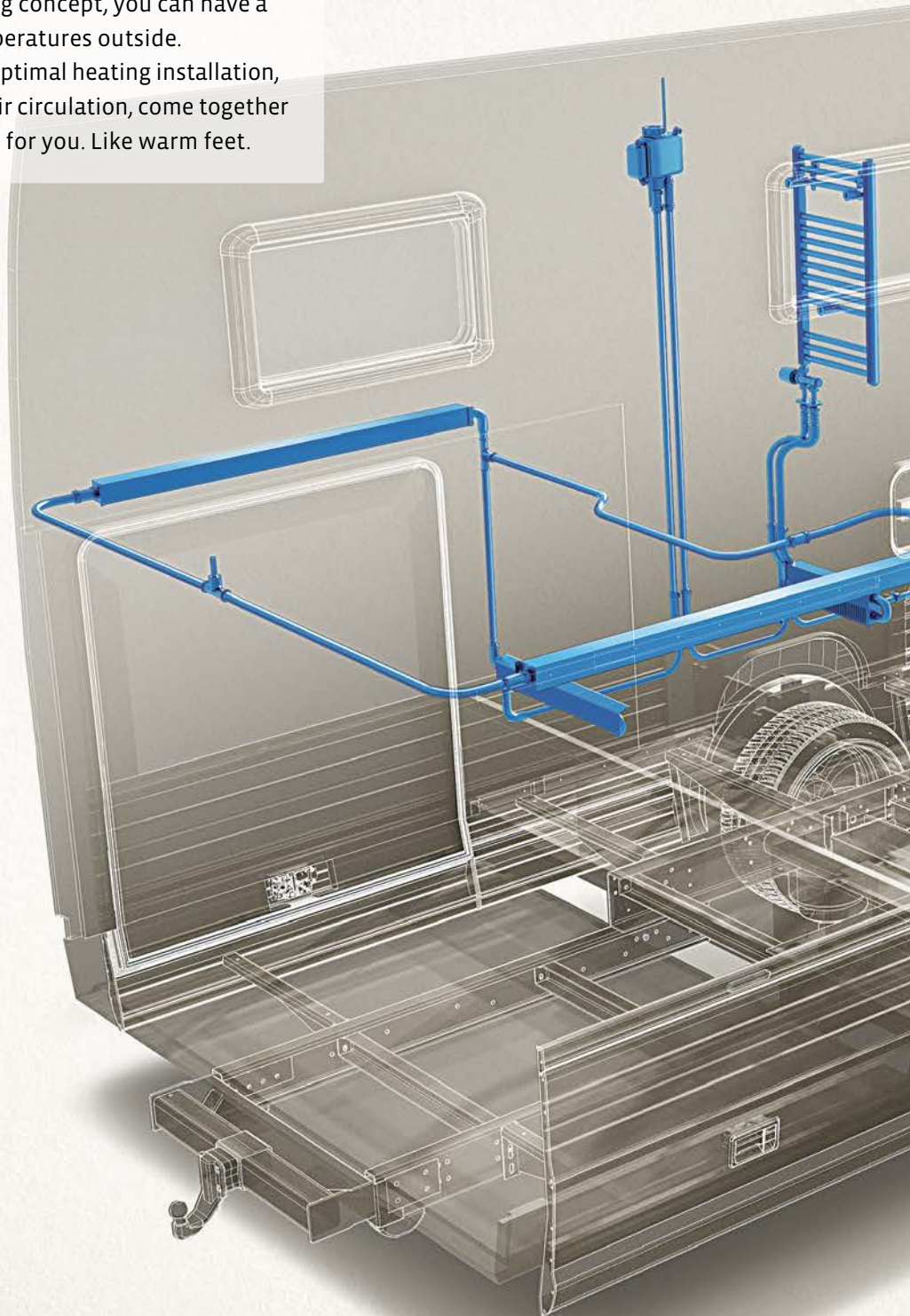

Thanks to additional rear walls behind cabinets and cushions, the air can also circulate behind the furniture and the heat from the heaters can disperse throughout the entire room.

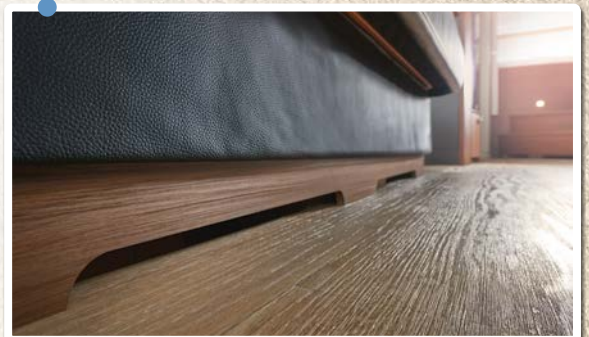
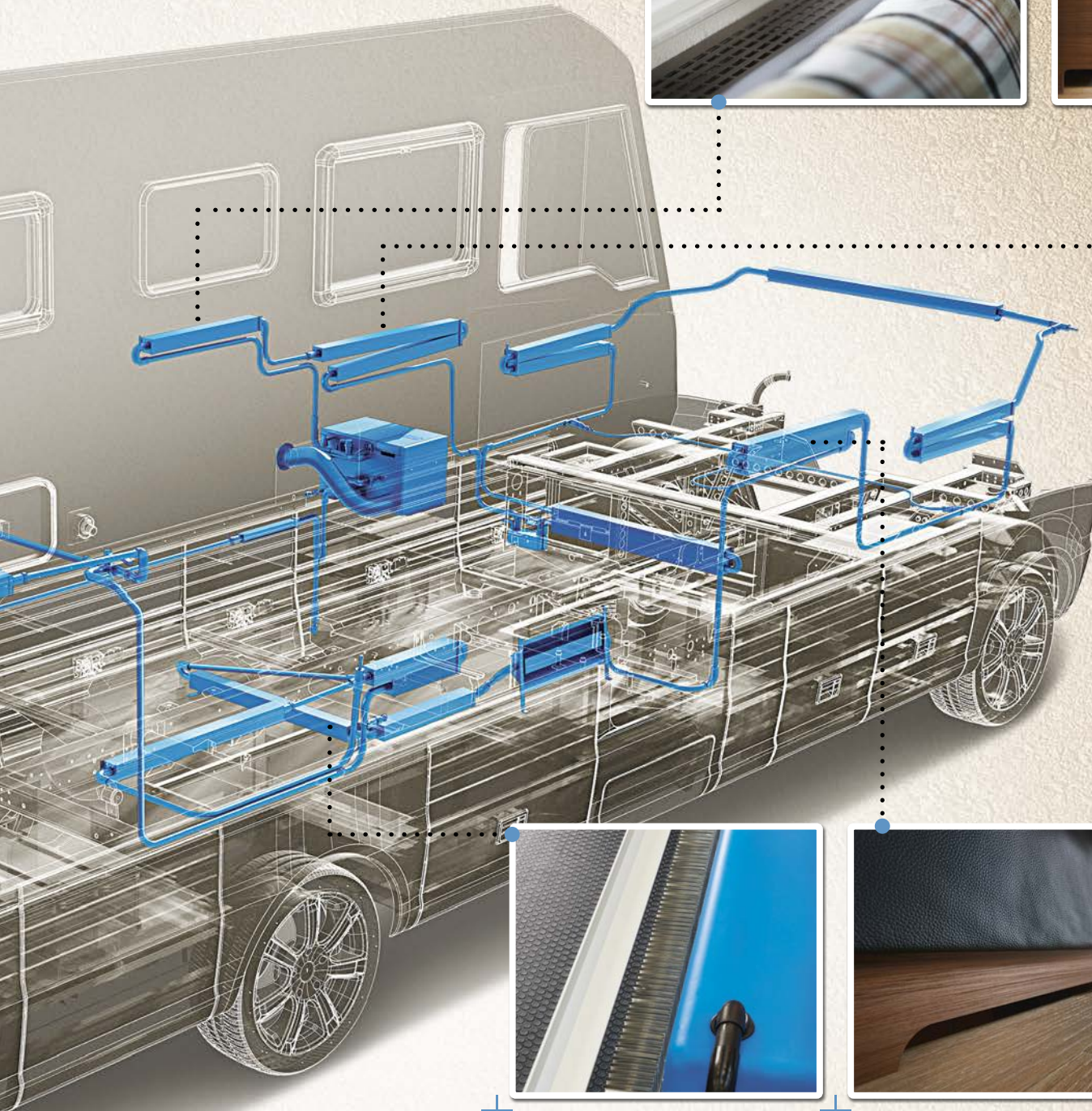

Convector heaters in the double floor protect all the fittings from cold weather. The double floor also serves as a storage heater and gives off heat to the floor similar to underfloor heating. Fully functional underfloor heating is available as an additional optional extra.

The warm air from the floor also gets into the circulation through small air vents in the seat benches. It comes up again behind the furniture and is dispersed evenly throughout the entire room. This prevents build-up of heat at individual places.

DOUBLE-SIDED ALUMINIUM. A GOOD IDEA, WHICH WE HAVE MADE BETTER.

Whether it's a summer or a winter holiday, you can always get caught cold by the weather. Or caught in a sweat. We have ensured that the temperature always feels just right on your holiday. We have been making panels from double-sided aluminium for more than 30 years and have been improving the material since the beginning. The structure is simple – aluminium on the outside, styrofoam on the inside. In this composition, the panels are virtually non-conductive – heat and cold have to stay outside. And to ensure an insulation all around, we don't just use this material in the rear and side panels, but also in the double floor and in the exterior storage doors. But despite all this insulation, we'll also keep our fingers crossed for good weather, of course.

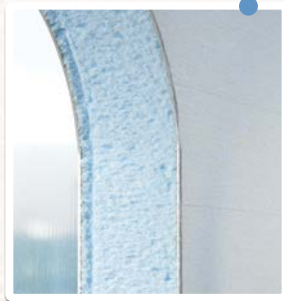

We use aluminium on the outside and styrofoam on the inside, based on the sandwich principle, so that the walls don't conduct either heat or cold.

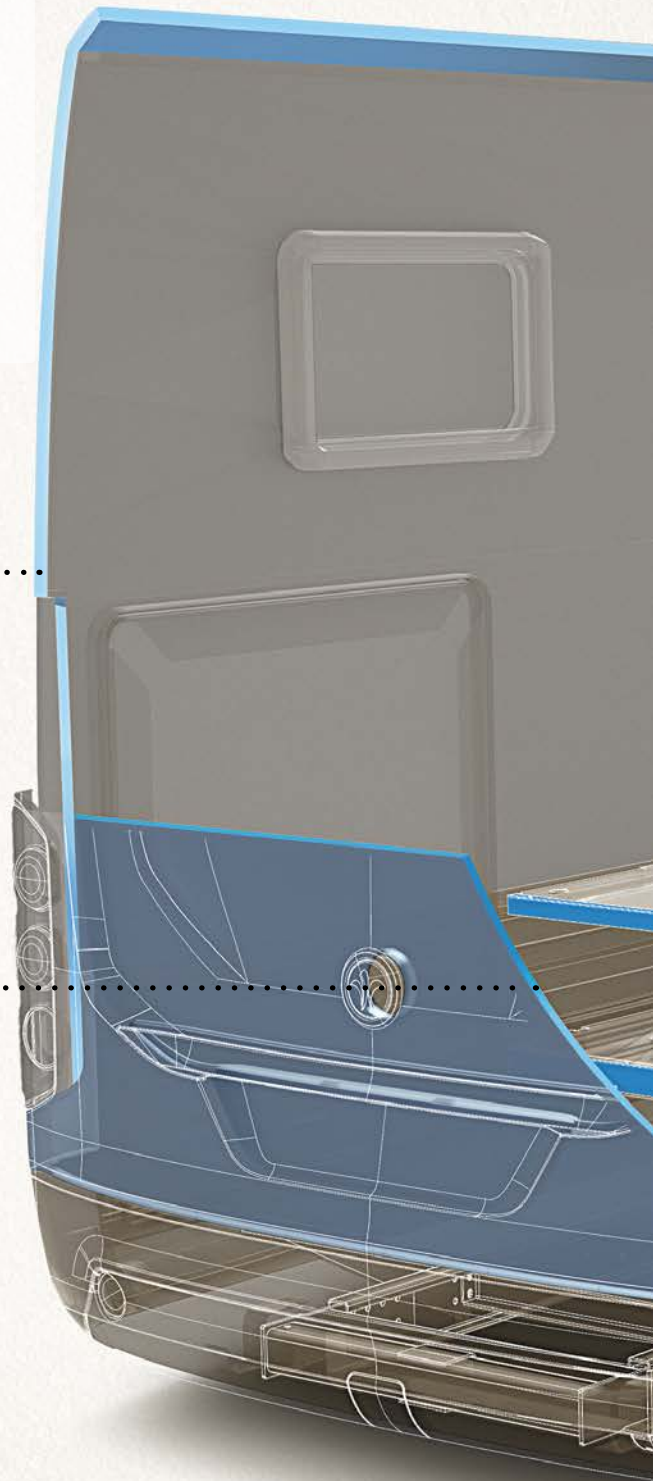

The connection between the roof and the side walls is also free of cold bridges thanks to double-sided aluminium.

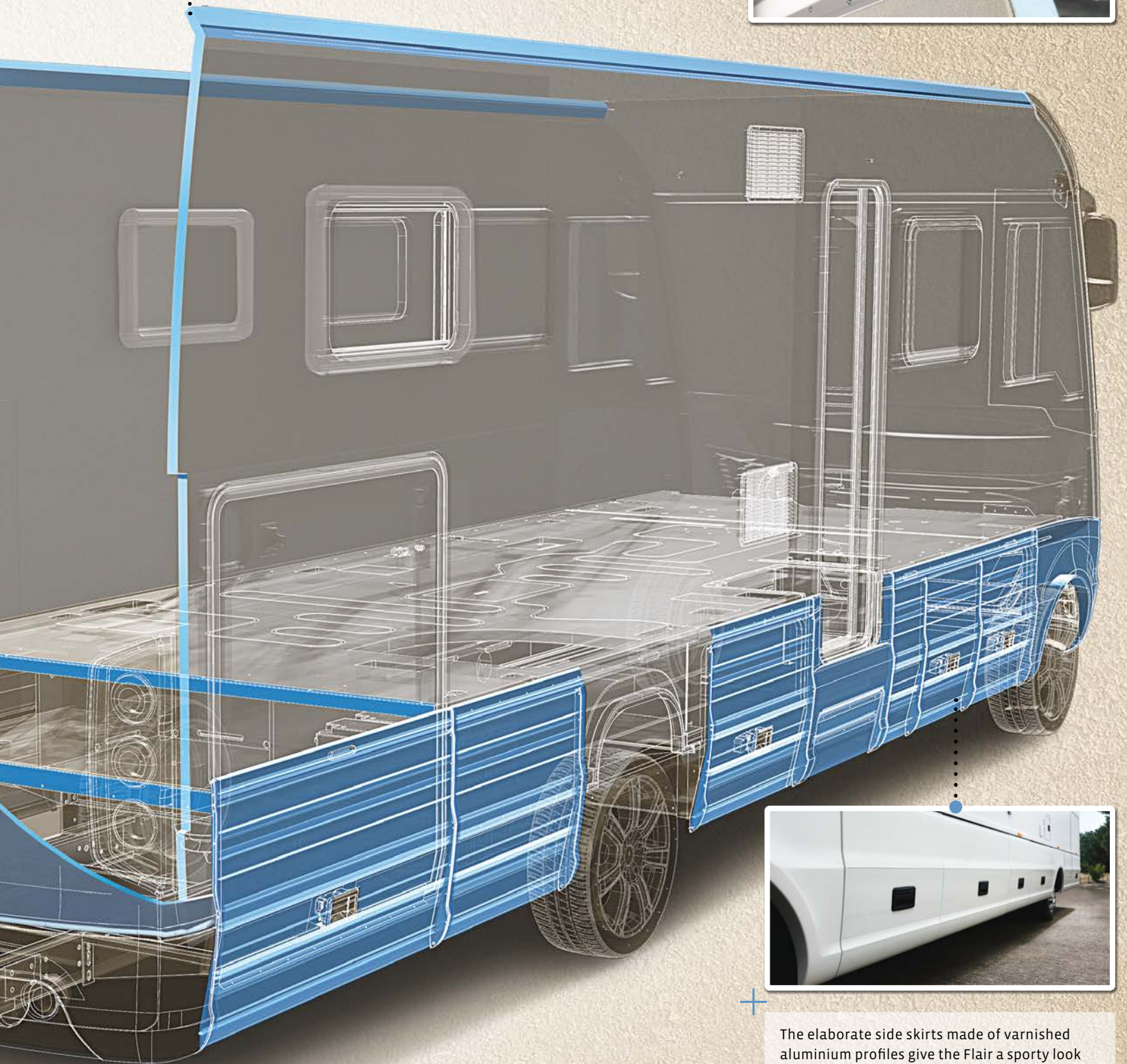
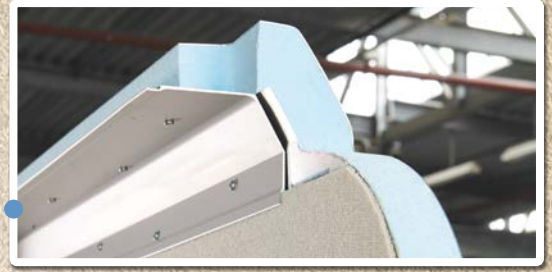

The elaborate side skirts made of varnished aluminium profiles give the Flair a sporty look on the outside. They cover the chassis frame and the retracted outside step.

STILL ONE OF THE WARMEST PLACES ON A WINTER HOLIDAY.

Only when it is really cold outside can you see for yourself that we have found a solution for a cosy, warm interior in our models, even in difficult places. If you tend to spend your holidays in colder places, we also offer you some extras that put an end to cold bridges and make your Niesmann+Bischoff a warm place that you always want to come home to.

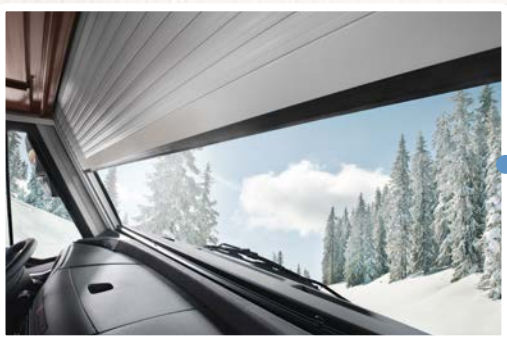

We had to come up with something special for the large panoramic windscreen. They don't come in double glazing. The electrically operated and insulated front blind (optional) ensures that the cold stays outside, even here. The intervening space is also heated directly.



The rear ventilation on the windscreen works in conjunction with the convective heaters like a thermal screen.

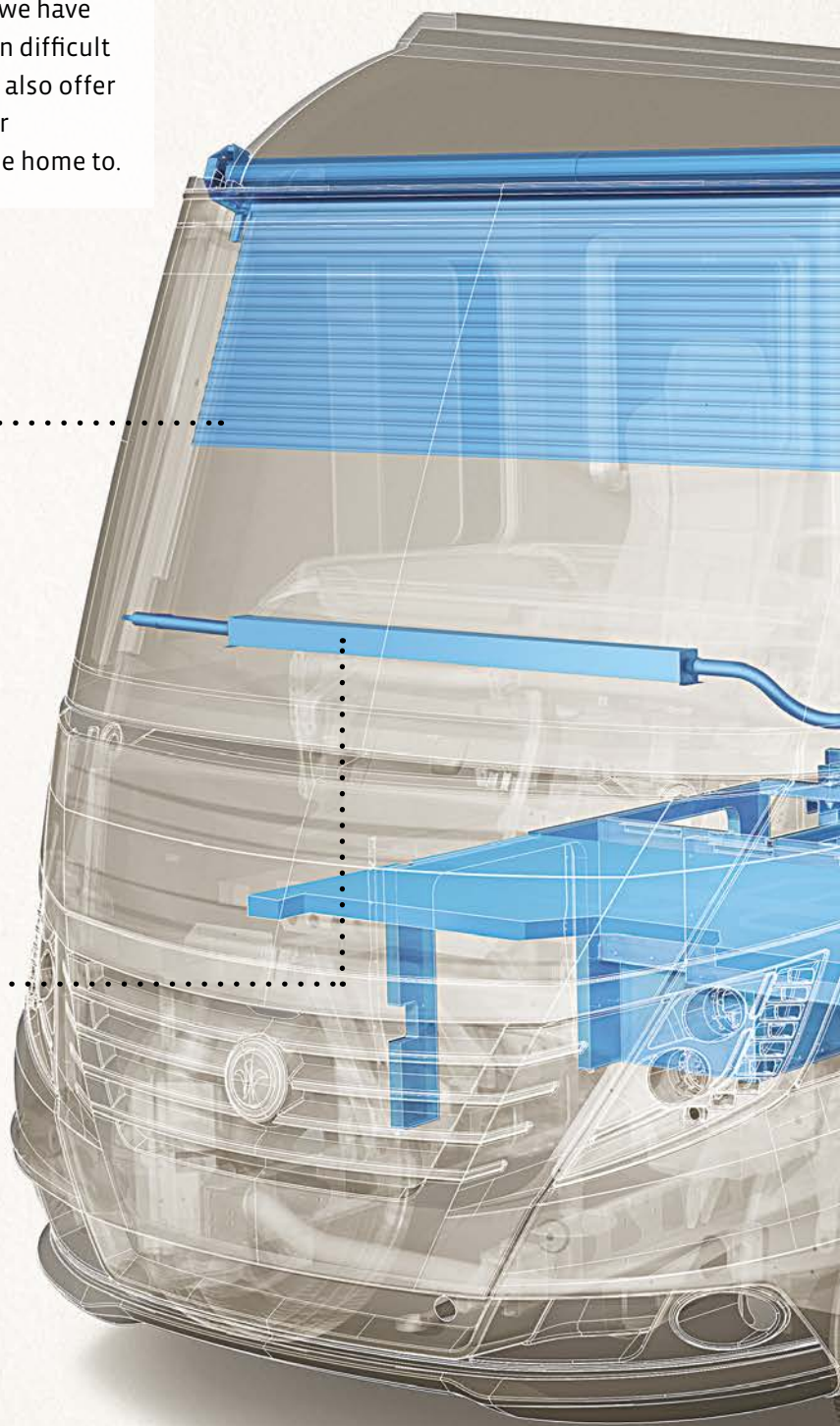

The optional Seitz S7 windows are double-glazed. They are easy to operate with one hand and have thermally broken aluminium outer frames.



The optional double-glazed side windows ensure better insulation and also offer up to 80% more heat protection than conventional, single-glazed side windows.



The underfloor is made entirely of double-sided aluminium sandwich. The upper floor serves as a heat-store and ensures that the interior of the vehicle is very well insulated.

THE HIGHEST QUALITY, PARTICULARLY ON THE ROOF.

Not everything that comes from above is good. Hail, branches, stone chips, incessant rain and occasionally even footballs – the roof of a motorhome has to deal with a lot of things. And we have done everything in our power to develop the perfect material for the roof of our motorhomes. And the result: glass-reinforced plastic with extra-high glass content. The additional gelcoat finishing makes the roof extremely robust and scratch-proof without affecting its lightweight design style. In doing so, we have also greatly increased the flexural rigidity.



The flush-mounted transition from the front mask to the roof prevents back-pressure of water and ensures that the water runs off to the front.



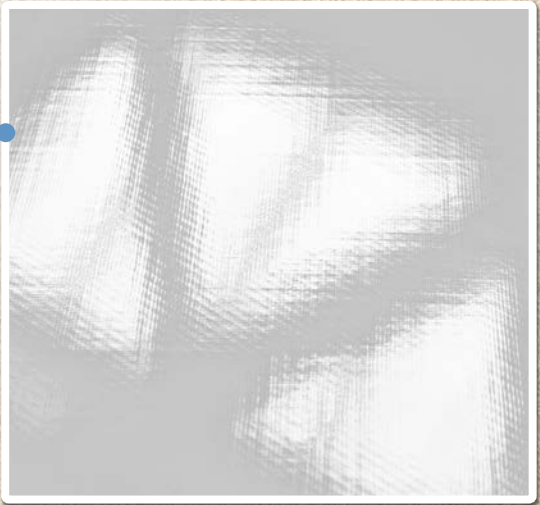
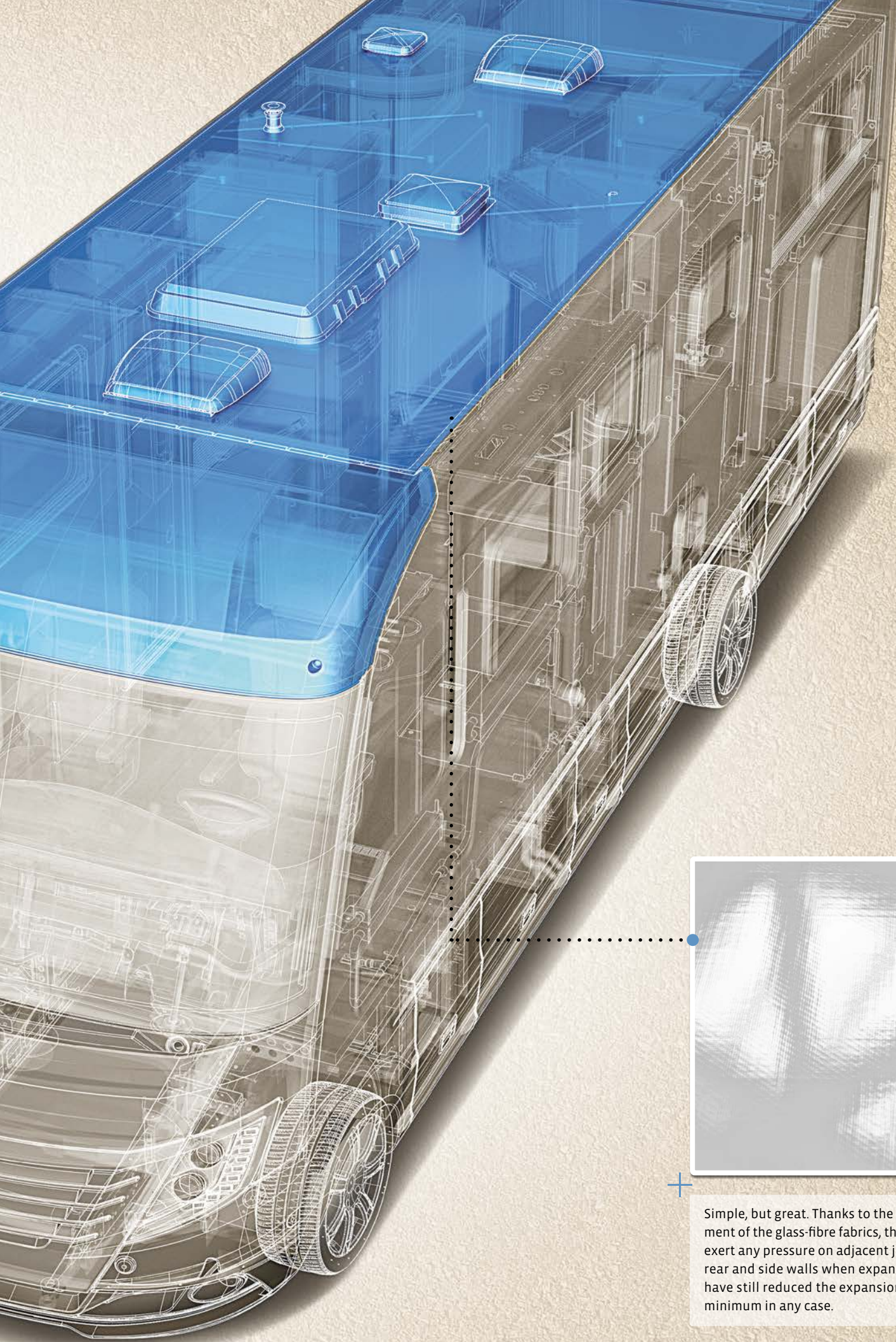

Simple, but great. Thanks to the diagonal arrangement of the glass-fibre fabrics, the material cannot exert any pressure on adjacent joinings to the front, rear and side walls when expanded. However, we have still reduced the expansion properties to a minimum in any case.

SEVEN

RATHER THAN THREE,

+ IN CASE YOU'RE NOT PAYING ATTENTION.

A Flair is big, but there's still no space for certain things - like dents at the front and rear, for example. So we put on our thinking caps and came up with a solution. Or rather seven solutions. This has a number of benefits. For one, some parts can be changed more cheaply than others; secondly, this enables quicker access to the cooler and engine bay.





We manufacture all parts from extremely wear- and scratch-resistant GRP. And the best thing of all about this material: small scratches can be polished away using gelcoat paste, while larger scratches are taken care of with a special surfacer.



YOUR FIRST TWO HOLIDAY DESTINATIONS: DRIVING PLEASURE AND SAFETY.

You and your new Flair will discover many new holiday destinations together, clocking up thousands of miles en route. We have invested a lot of time and engineering in your driving pleasure and safety, so your holiday can begin before you even hit the road. And if you'd like to reach your destination even more relaxed, a few little extras can make travelling in a Flair an even more comfortable experience.

Of course, we all like to look in front of us. But to make sure you reach your destination safely, it's important to look back regularly as well – using our large wing mirrors (Liner pack) with wide-angle field and few blind spots.



Thanks to the optional rear-view camera, you've got the best views of the concealed area behind the closed rear wall.

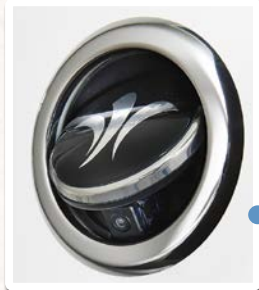

The body door and garage door are equipped with two-fold locking and electrical closing.

Your back will savour every mile it travels in our comfortable SKA seats (Liner pack). They adapt perfectly to the contours of your body. You can raise or lower the seat by 120 mm, for example, extend or even tilt it. But don't forget to take little breaks, too; simply turn both seats around 180 degrees, fix them in place, push back the back rest, then put your feet up on the sofa and close your eyes.

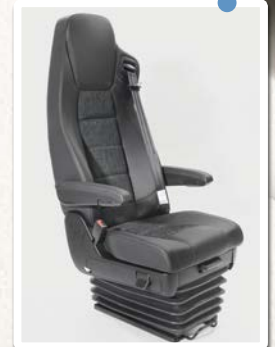

The LED daytime running lamps perfectly match the automotive design and guarantee optimum illumination of the road as well as perfect night vision.



Beautiful weather. But it's a good thing the standard gradient tint and the tinted windscreen mean that you don't need to squint your eyes while driving.



If the gradient tint is not enough, you can also darken the panoramic windscreen with the electrical front blind (optional) – but not so dark, of course, that you can't see the road in front.



THE BEAUTIFUL SIDES OF YOUR HOLIDAY.

Did you know that people fall in love quicker on holidays than at home? With our Flair comfort liner, it's often love at first sight. Its automotive design and sporty look with convex and concave shapes catch the eye right away. As our Arto was recently victorious in the 2014 Automotive Brand Contest and received the Red Dot Design Award, we are excited to see the reaction of the juries to the new design of the Flair.

The new Niesmann+Bischoff face emphasises the width and dynamic nature of the vehicle - accentuated by the unique daylight blinker modules, the subtle chrome details and the brand logo placed at the front and centre.



'Thrilling surfaces' - convex and concave muscles and edges create fascinating light effects and lend structure to the surfaces.

The visor unit is well proportioned and stretches the vehicle visually. A bold window line on the side ensures a clear structure.

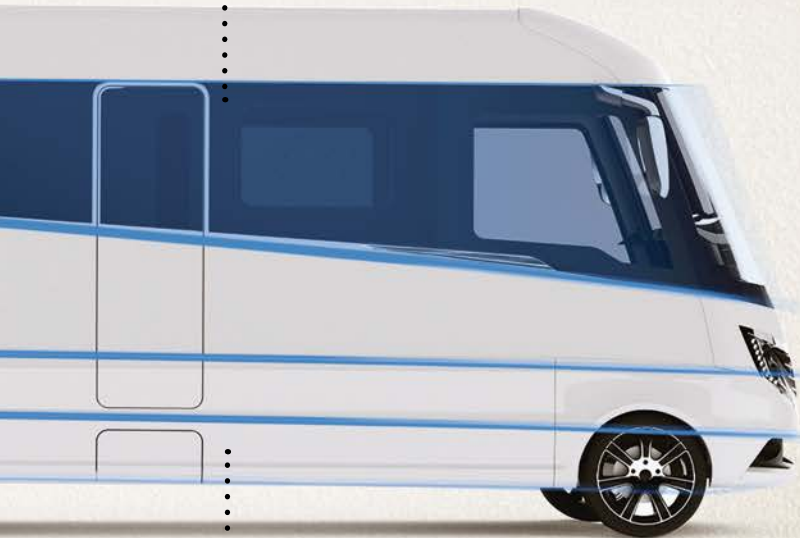

Structures are channelled directly to the rear through the wheel area and sill. The connection between the front and rear is a key element in the vehicle's integrative design.



The rear is topped off by LED tail lights with the unique, threefold night signature and the perfectly integrated, dirt-proof rear-view camera (optional) set behind the logo.



At the rear, the chrome trim continues the subtle edges and muscular surface structure of the aerodynamic cut-off edge on the tail section.



OUR MOTORHOMES ARE READY TO TAKE TO THE ROAD AFTER THESE TESTS.

To guarantee the highest level of quality, we really need to know our stuff. After we have proceeded meticulously through each planning and production step, our first model, the prototype of an entire series, must come through a range of tests. Then, and only then, when it has come through all the tests with flying colours, do we start production of a model like the Flair. And continue testing.





We sent the Flair to a very special test track. Here it met with very strong vibrations, so that after 100 laps, it had been subject to a stress corresponding to over 60,000 miles on the road. This allows us to uncover any weak spots right away and fix them quickly.



TESTS, TESTS AND + MORE TESTS.

A holiday is full of surprises. Also when it comes to road surfaces, unfortunately. Thankfully, you're prepared for all manner of wilderness with a Flair. Before a vehicle leaves our factory, we put it to the test on our own test track where it comes face to face with sine waves, potholes, concrete waves and bumpy paving. The surfacing on our track is more extreme than in a natural environment, but if the Flair can come through here, it can come through anywhere.

And then we carry on testing. Next, it's time for each model to undergo the obligatory leak test. Not with regular water. We take common rainwater, which, thanks to its low surface tension, can really show up any leak. For this test, we collect rainwater in our own cistern.

After so much rain, it's time for some sun – because after all these tests, the Flair is finally ready to travel the world with you.



WE'VE REACHED THE FINISH LINE: NOW YOU CAN HIT THE ROAD.

Your Flair is ready! Finally, you can turn the ignition key and start it up. With the anticipation of an unforgettable holiday. With that new vehicle fragrance in your nose. With the certainty of always arriving safely. With the feeling of driving a car. With the freedom of taking a break whenever you like and turning the driver's seat into a recliner. With the assurance that you can get a good night's sleep anywhere. With the luxury of a shower like in your own home. With the tranquillity you feel after spending a little time on your own. And with the possibility that tomorrow you might just discover the most beautiful place in the world. With the best ideas for your holiday.





IMPRINT

Subject to errors and changes. After the editorial deadline (07/2014), there may be changes to the models, products, plans, technical information, features, illustrations, etc. The illustrations also contain special features and/or accessories which are not part of the standard features or decorations in the Niesmann+Bischoff product range. Illustrations may be inaccurately depicted due to graphical conversion, image editing or technical production factors.

PUBLISHER

Niesmann+Bischoff GmbH
Clou-Str. 1 | 56751 Polch | Germany
T +49 2654 933-0
F +49 2654 933-100
M info@niesmann-bischoff.com
W niesmann-bischoff.com

CONCEPT AND DESIGN

BUTTER. GmbH

PHOTOGRAPHY

mooi – STARKE FOTOGRAFIE

TECH. PRESENTATION + RENDERINGS

Studio SYN

PRINTING

Druckstudio GmbH

FLAIR/ CATALOGUES MODELS 2015/
GB (V07/2014)

NIESMANN-BISCHOFF.COM