



GAMMA 2011

NEL PASSATO SI SCRIVE LA STORIA DEL FUTURO



60 ANNI DI COMPROMESSO CON IL FUTURO



Elnagh ha compiuto 60 anni. Un tripudio di innovazione, dalla tecnica alla tecnologia, perché il mondo va avanti, trainato da Elnagh.

Un'idea via l'altra, è così che Elnagh ha virato alla boa del mezzo secolo e ora veleggia verso i cento anni, mossa sempre dallo stesso entusiasmo che le ha permesso di essere grande durante tutti questi anni. Quando un'azienda è vitale e briosa come Elnagh, ogni prodotto è un successo amato dai clienti e apprezzato dalla critica di settore, basti pensare agli articoli scritti dai viaggiatori su Andiamo, la storica rivista di Elnagh.

Elnagh non è solo un marchio, Elnagh è un modo di pensare sempre rivolto al domani, in anticipo sui tempi e riconoscente alla storia.

Per festeggiare il suo anniversario Elnagh ha deciso di presentare il nuovo Magnum, storico motorhome dal passato glorioso. Una cosa è certa. Con Elnagh non ci si ferma mai: le scoperte di domani sono già in cantiere.





NEL PASSATO SI SCRIVE LA STORIA DEL FUTURO



Elnagh da 60 anni crea, innova e rielabora il concetto di movimento. Dalla forcella elastica per biciclette a motore all'autocaravan, Elnagh esprime tutta la sua ingegnosa milanesità con la stessa creatività che l'Eden della moda sprigiona con i tessuti. Grazie al suo parco circolante, uno tra i maggiori in Europa, Elnagh è il marchio più riconosciuto sulle strade e nei campeggi. Elnagh oggi non ha bisogno di grandi giri di parole perchè ogni prodotto racchiude ciò che da sempre contraddistingue il suo marchio e la sua storia: tecnica, inventiva e determinazione.

Grazie ai giovani inventori, gli abili artigiani, i progettisti e i designer, Elnagh è un'azienda che gioca regolarmente d'anticipo, offrendo soluzioni funzionali e eleganti con quell'attenzione al dettaglio che solo una solida esperienza può offrire. Marco Polo conosceva le stoffe pregiate, Michelangelo era Maestro d'arte, Cristoforo Colombo studiava le rotte. Elnagh crea camper. Un camper Elnagh è un gioiello di precisione e comfort.



GAMMA BARON

GAMMA BARON PLUS

ELNAGH TI ACCOGLIE IN FAMIGLIA

Se non sei mai salito su un camper Elnagh, Baron fa il caso tuo. Baron è il camper perfetto per chi vuole prendere i bagagli e partire senza condizioni. Baron è caldo se vuoi andare a nord e fresco se vuoi andare a sud, è confortevole d'inverno e piacevole d'estate. Elnagh ha già pensato a tutto, tu gira la chiave.



Pannello di controllo su porta di ingresso con interruttore generale.

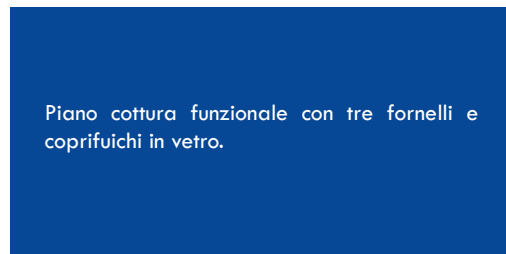

Piano cottura funzionale con tre fornelli e coprifuochi in vetro.



Ampio garage e fanali posteriori orizzontali per una maggiore visibilità.

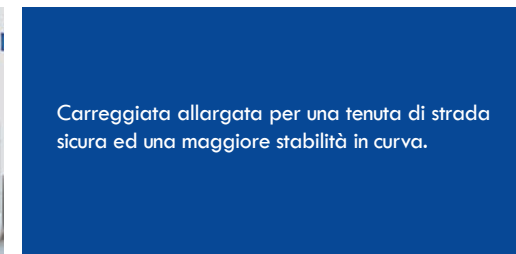

Carreggiata allargata per una tenuta di strada sicura ed una maggiore stabilità in curva.

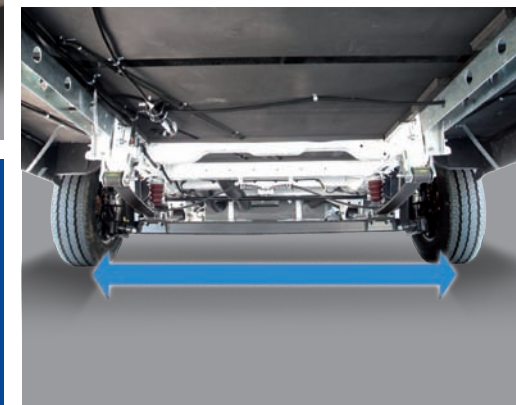

GAMMA BARON MODELLI MANSARDATI



BARON 37



BARON 46



BARON 47D



GAMMA BARON SEMI-INTEGRALI



BARON 420L



BARON 580L



elnagh

BARON 47D



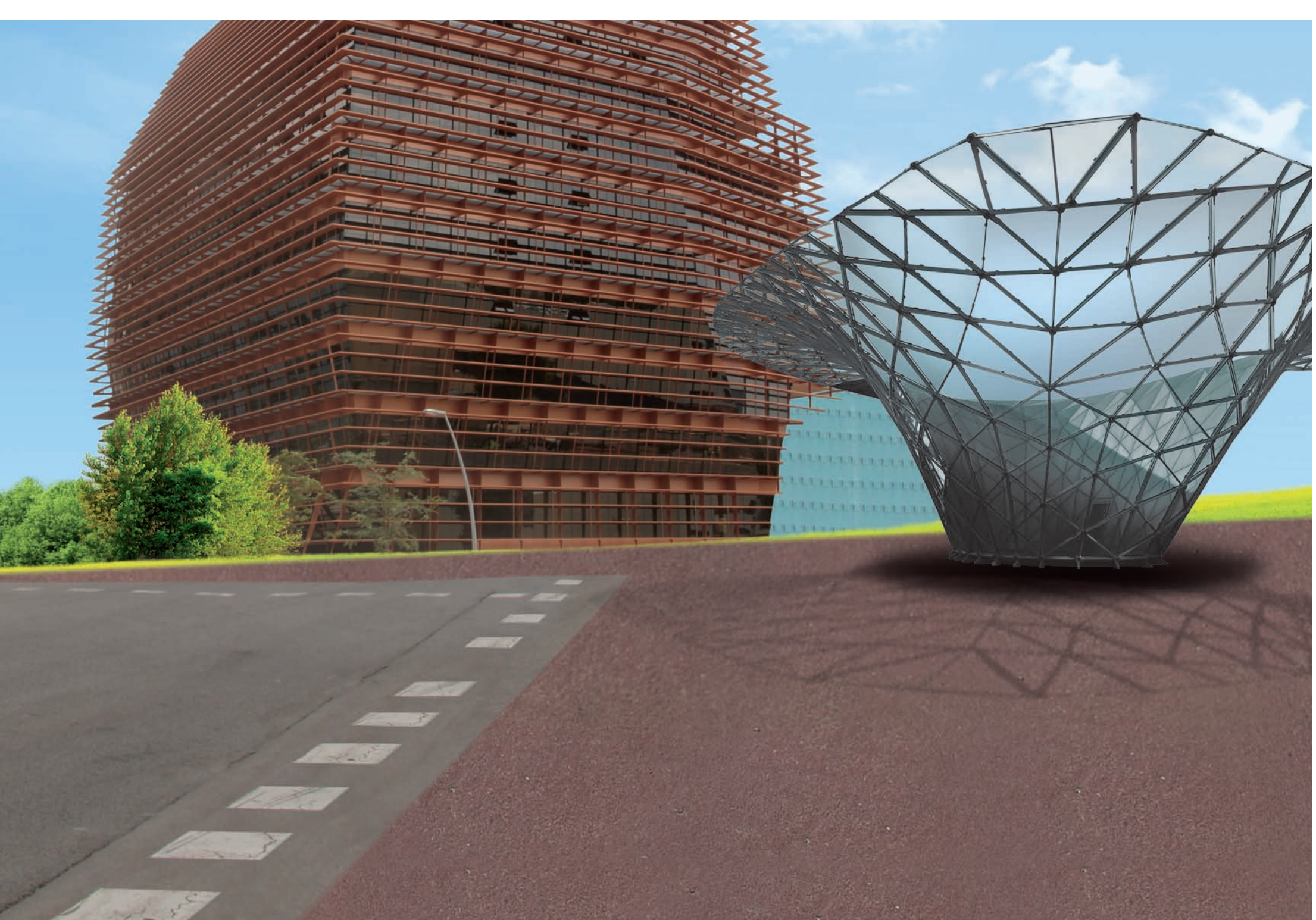

BARON 47D





elnagh

BARON 580L





BARON 580L





GAMMA DUKE

GAMMA DUKE PLUS

CREATIVITÀ IN MOVIMENTO

Ogni vacanza è un giusto equilibrio di benessere, avventura e relax. Duke ti offre tutto insieme. La libertà di viaggiare agilmente alla scoperta di posti nuovi, il piacere di dormire fra due guanciali per poi tornare a casa soddisfatto e ritemprato.

Duke. Creatività in movimento.



Finestra cellula Seitz con cornici in poliuretano.



Nuovo design aerodinamico per la finestra sul profilo della mansarda



Carreggiata allargata per una tenuta di strada sicura ed una maggiore stabilità in curva.

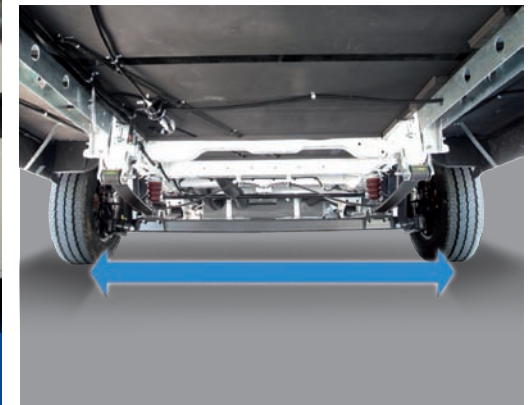

GAMMA DUKE MODELLI MANSARDATI

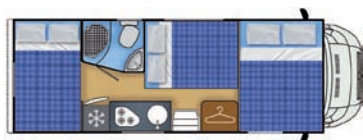

DUKE 46



DUKE 55



DUKE 57D

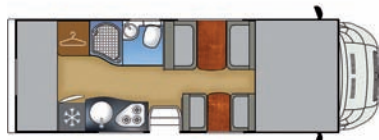
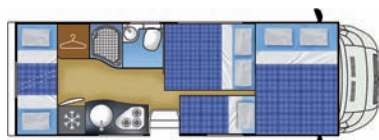



elnagh

DUKE 46



DUKE 46













DUKE 55





GAMMA T-LOFT

GAMMA T-LOFT PLUS

L'habitat naturale per chi vuole spazi non convenzionali doppiamente innovativi.
T - Loft è il piacere di viaggiare senza confini in perfetto stile Elnagh.



Letto basculante di 140x200 cm.

Finestra cellula Seitz con cornici in poliuretano.



Frigo grande da 150 lt.



Presa esterna multifunzione per TV 12V, TV 220V e antenna satellitare.

Carreggiata allargata per una tenuta di strada sicura ed una maggiore stabilità in curva.

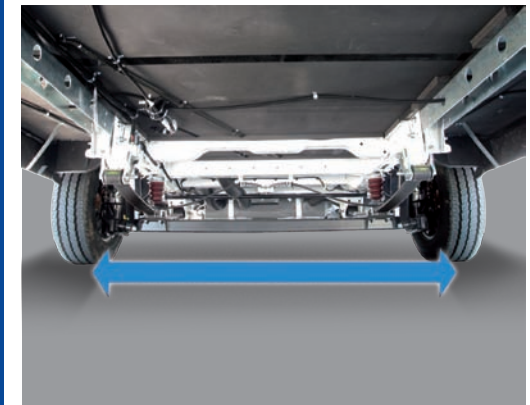

GAMMA T-LOFT SEMI-INTEGRALI



T-LOFT 31



T-LOFT 45



T-LOFT 53



T-LOFT 58



elnagh

T-LOFT 53



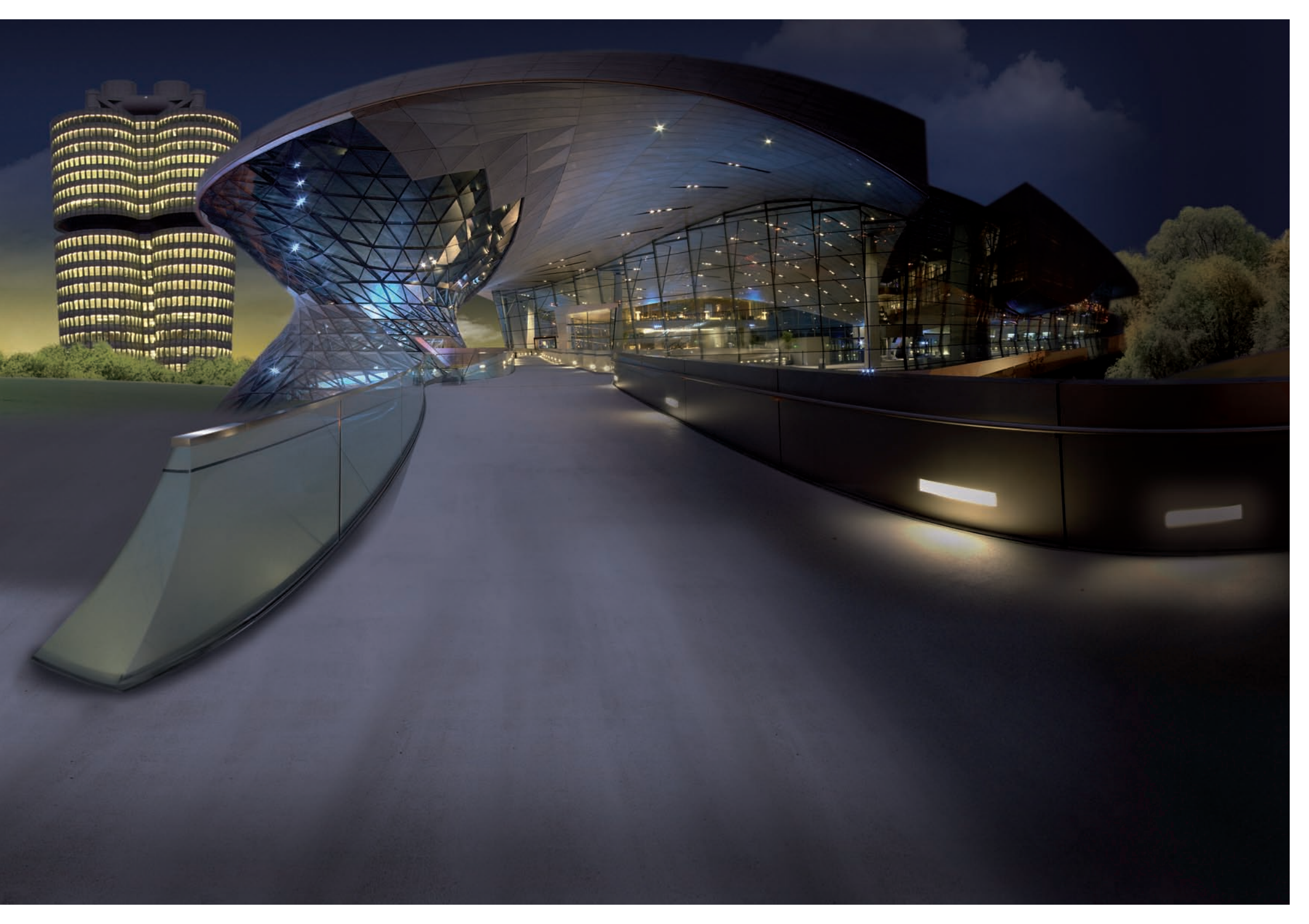

T-LOFT 53





T-LOFT 53





T-LOFT 53





T-LOFT 58



T-LOFT 53

GAMMA PRINCE

GAMMA PRINCE PLUS

LE RISPOSTE PRIMA DELLE DOMANDE.

Elnagh conosce i suoi ospiti più esigenti, per questo ha creato Prince. Prince ha tutto ciò che vuoi per una vacanza perfetta: arredo dalla linea morbida, rivestimenti dai colori accattivanti, accessori di design. Con Prince i tuoi viaggi hanno sempre un qualcosa in più, più stile, più comfort, più vacanza.

Prince. Le risposte prima delle domande.



Mansarda dalle forme slanciate ed aerodinamiche. Colonne Pillar Window, progetto originale Elnagh, per una maggiore visibilità.



Bandella di raccordo portiera dal design integrato ed aerodinamico.

Testata posteriore dal design caratterizzante con gruppi ottici integrati nelle colonne che confluiscono nel paraurti



Design di stile nautico per il moderno cupolino con Sky - Dome integrato.





Sky – Dome per una maxi luminosità degli interni, dotato di oscurante.



Funzionale prolunga pieghevole che consente di avere un posto letto aggiuntivo in dinette.



Comfort ad alti livelli grazie alla gamba telescopica del tavolo che trasla orizzontalmente e verticalmente.

Piano cucina in vetroresina dal design moderno e funzionale grazie alla grande vasca integrata.



Antine con pistoni laterali per una apertura morbida, in perfetto stile automotive.



Porta Seitz con finestra e zanzariera integrate per una maggiore vivibilità interna.

GAMMA PRINCE



Controllo centralina con schermo LCD.
Rilevamento di temperatura interna ed esterna.



Nuove grafiche alleggerite, dal design slanciato e moderno.



Copricerchi brandizzati con logo Elnagh resinato in rilievo.

Nuovo porta TV orientabile con guide rinforzate per garantire una minore torsione ed una maggiore stabilità.



Presca esterna multifunzione per TV 12V,
TV 220V e antenna satellitare.

Terza luce di stop integrata nel design del termoformato posteriore.



Lettering elegante in rilievo e resinato.

Finestre Seitz con telaio in alluminio integrato nel design delle fiancate in vetroresina.



GAMMA PRINCE MODELLI MANSARDATI

GAMMA PRINCE SEMI-INTEGRALI



PRINCE 46

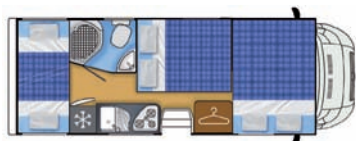

PRINCE 47



PRINCE 55L



PRINCE 57



PRINCE 530L



PRINCE 570L



PRINCE 580L



PRINCE 581



PRINCE 590L



PRINCE 590L

PRINCE 590L



PRINCE 590L

PRINCE 590L



PRINCE 590L

PRINCE 590L



PRINCE 590L



elnagh

PRINCE 55L



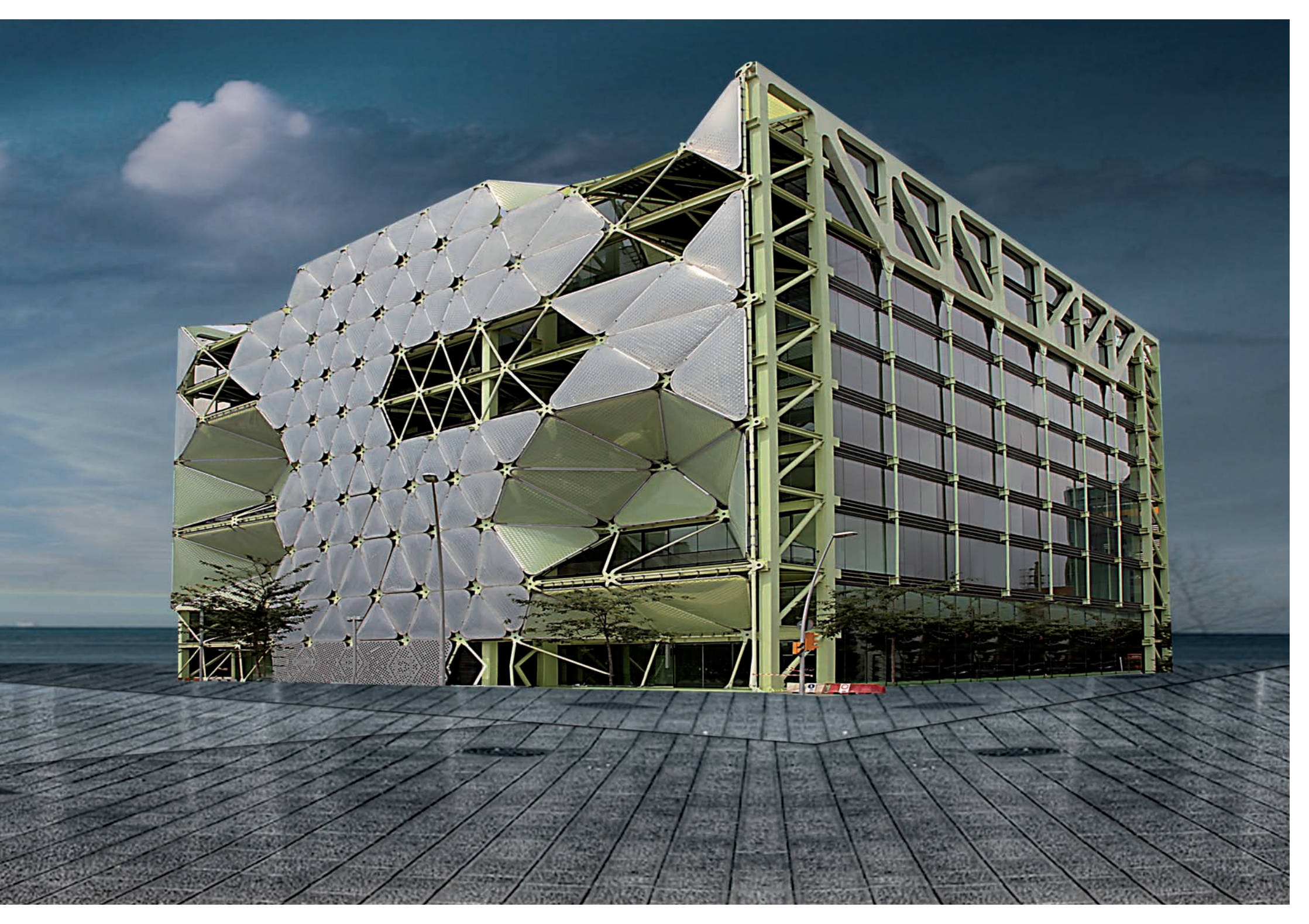

PRINCE 55L





PRINCE 55L





elnagh

PRINCE 530L





PRINCE 530L





PRINCE 530L





PRINCE 581





GAMMA MAGNUM

GAMMA MAGNUM PLUS

Lascia a casa il lavoro, la città e la frenesia. Sali su Magnum e parti! Con Magnum ogni meta è già raggiunta perché il primo traguardo è proprio il tuo Magnum.

Magnum è il top di casa Elnagh: maestoso, elegante ed accogliente.

Se vuoi ciò che gli altri ammirano solo da fuori, scegli Magnum.

Viaggiare con Magnum è un piacere esclusivo.

Business Class? No, Magnum Class!



Testata posteriore dal design caratterizzante con gruppi ottici integrati nelle colonne che confluiscono nel paraurti.



Realizzati con materiale traspirante, i sedili Aguti sono ergonomici e con un comfort di seduta che garantisce una guida riposante. La struttura interna rinforzata e la cintura di sicurezza integrata garantiscono una guida sempre in sicurezza.

Fari anteriori di design per una visibilità massima in ogni condizione.



Controllo centralina con schermo LCD. Rilevamento di temperatura interna ed esterna.



Copricerchi brandizzati con logo Elnagh resinato in rilievo.



Piano cucina in vetroresina dal design moderno e funzionale grazie alla grande vasca integrata.

Antine con pistoni laterali per una apertura morbida, in perfetto stile automotive.



Nuovo porta TV orientabile con guide rinforzate per garantire una minore torsione ed una maggiore stabilità.

Carreggiata allargata per una tenuta di strada sicura ed una maggiore stabilità in curva.

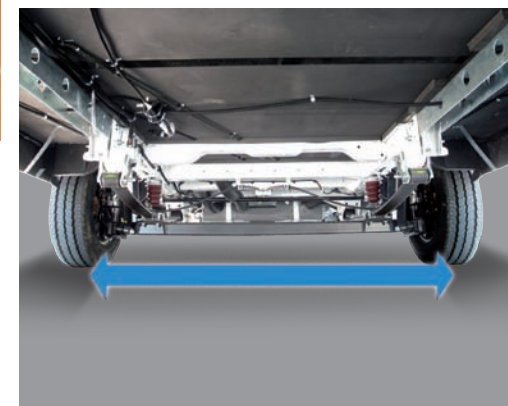

MAGNUM



Porta Seitz con finestra e zanzariera integrate per una maggiore vivibilità interna.

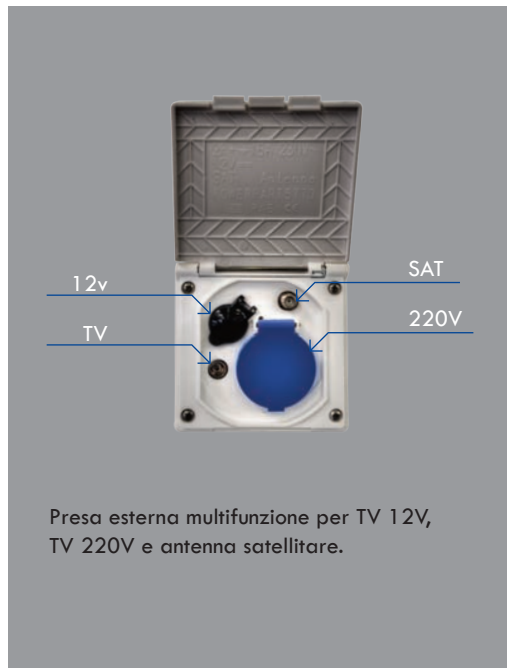

Terza luce di stop integrata nel design del termoformato posteriore.



Finestre Seitz con telaio in alluminio integrato nel design delle fiancate in vetroresina.

MAGNUM

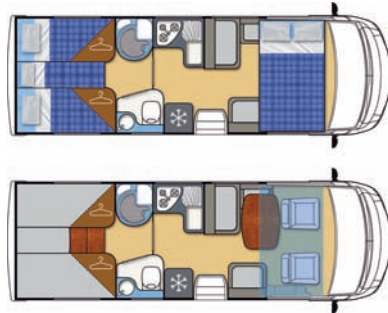

MAGNUM 30

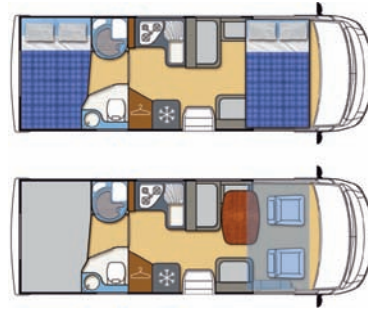

MAGNUM 70



elnagh

MAGNUM 30





MAGNUM 30





MAGNUM 30





MAGNUM 30





MAGNUM 30





SINTESI PIANTINE

GAMMA BARON MODELLI MANSARDATI



BARON 37



BARON 46



BARON 47D

GAMMA BARON MODELLI SEMI-INTEGRALI



BARON 420L



BARON 580L

GAMMA DUKE MODELLI MANSARDATI

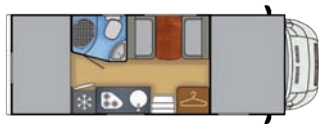

DUKE 46

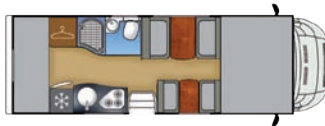

DUKE 57D



DUKE 55

GAMMA T-LOFT MODELLI SEMI-INTEGRALI



T-LOFT 31



T-LOFT 45



T-LOFT 53



T-LOFT 58

GAMMA PRINCE MODELLI MANSARDATI



PRINCE 46



PRINCE 47



PRINCE 55L



PRINCE 57

GAMMA PRINCE MODELLI SEMI-INTEGRALI



PRINCE 530L



PRINCE 570L



PRINCE 580L



PRINCE 581



PRINCE 590L

GAMMA MAGNUM MODELLI MOTOR HOME



MAGNUM 30



MAGNUM 70

GAMMA DOTAZIONI DI SERIE ED OPZIONALI COMUNI A TUTTI I MODELLI ELNAGH

DOTAZIONI DI SERIE STRUTTURALE

PAVIMENTO 70 mm

Pavimento eccezionalmente configurato, con uno spessore di 70mm: dimensione che non trova riscontri nel settore camping car. Lo studio è stato effettuato col fine di ottenere un ottimo livello di coibentazione ed insonorizzazione. Da sottolineare, inoltre, la robustezza e la rigidità torsionale ad elevate performance.

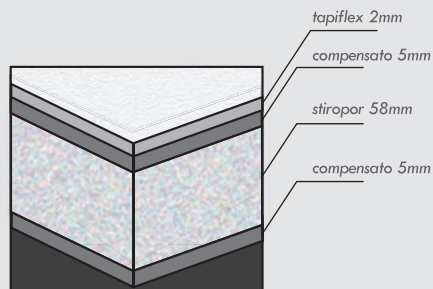

PARETI E TETTO IN FIBRA DI VETRO

La combinazione di materiali utilizzati per la realizzazione delle pareti permette di dare ottimi risultati in termini di confort acustico, termico e di facilità di intervento in caso di riparazioni. La soluzione offerta è sensibilmente più efficiente di quelle che prevedono l'uso di alluminio, essendo quest'ultimo un conduttore di freddo, caldo e rumore molto più elevato della fibra in vetro.

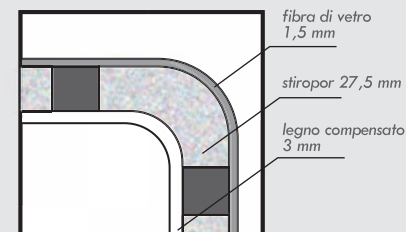

Miglioramento tecnico della scocca. Agglomerato con le seguenti caratteristiche tecniche:

- Antimuffa
- Idrorepellente
- Resistente ad elevato carico meccanico
- Resistente al fuoco
- Resistente agli acidi
- Temperature di utilizzo -50°C/+100°C
- Indeformabile
- Isolante

DOTAZIONI DI SERIE ABITACOLO

RISCALDAMENTO CANALIZZATO IN MANSARDA (PER MODELLI MANSARDATI)
TERMOVENTILAZIONE
CENTRALINA ELETTRICA CON CARICA BATTERIA
PRESA 12V E 220V, TV-SAT (INTERNA)
CINTURE DI SICUREZZA A TRE PUNTI
SERBATOIO ACQUA 100 LITRI
SERBATOIO DI RECUPERO 100 LITRI
VANO PER BATTERIA DI SERVIZIO
W.C. THETFORD ESTRAIBILE A CASSETTA
VANO ESTERNO ISOLATO PER BOMBOLE (2x13kg.)
MATERASSO LETTI AD ALTA DENSITÀ
RETE PROTEZIONE LETTI MANSARDA (PER MODELLI MANSARDATI)
RETE PROTEZIONE LETTI A CASTELLO (OVE PREVISTI)
COPRIFUOCO CRISTALLO CON PARAFIAMMA
SCALETTA ACCESSO MANSARDA (PER MODELLI MANSARDATI)

DOTAZIONI OPZIONALI ABITACOLO

RAMPA ACCESSO GARAGE (PER VERSIONI CON GARAGE)
PIEDINI DI STAZIONAMENTO
OSCURANTI CABINA

DOTAZIONI DI SERIE TELAIO MOTORE

VERSIONE FIAT X250 2.200cc - 100CV (74KW)

IDROGUIDA
TRAZIONE ANTERIORE
AIRBAG LATO GUIDA
ABS
CRISTALLI ATERMICI
SEDILE LATO GUIDA E PASSEGGERO REGOLABILE LONGITUDINALMENTE
SEDILE LATO GUIDA REGOLABILE IN ALTEZZA
SEDILI GIREVOLI SU MODELLI LIVING
VETRI ELETTRICI
CHIUSURA CENTRALIZZATA CON TELECOMANDO
MOTORE TIPO DIESEL EURO 4, CON CAMBIO A 5 MARCE
PNEUMATICI CAMPING CAR
CARREGGIATA ALLARGATA
PREDISPOSIZIONE RADIO
FIX & GO

VERSIONE FIAT X250 2.300cc - 130CV (95,5KW) E 3.00cc - 157CV (115,5KW)

TUTTE LE DOTAZIONI DELLA VERSIONE 100CV PIÙ:
MOTORE TIPO DIESEL EURO 4, CON CAMBIO A 6 MARCE
(1) PACK ELEGANCE (BARON 130CV, DUKE 130CV E PRINCE)
PARAURTI BIANCO (PRINCE)

DOTAZIONI OPZIONALI TELAIO MOTORE

CLIMATIZZATORE CABINA
TAPPETINI ANTERIORI IN MOQUETTE
(1) PACK ELEGANCE (BARON 100CV)
(2) PACK SAFETY (BARON 130CV, DUKE 130CV, T-LOFT, PRINCE E MAGNUM)
PARAURTI BIANCO (BARON E DUKE)

(1) PACK ELEGANCE

DOPPIO SPECCHIO ELETTRICO
CON SBRINAMENTO

PREDISPOSIZIONE RADIO CON
ALTOPARLANTI

ANTENNA RADIO

COPPE RUOTE INTEGRALI

DOPPIO BRACCIOLO SEDILI ANTERIORI

(2) PACK SAFETY

ASR

AIRBAG PASSEGGERO

CRUISE CONTROL

BARON

DOTAZIONI DI GAMMA E OPZIONALI

DOTAZIONI DI SERIE

RISCALDAMENTO E BOILER AD ACCENSIONE ELETTRONICA TRUMA C40

FINESTRE CON OSCURANTE E ZANZARIERA

3 PRESE 220V

LETTI POSTERIORI CON DOGHE PER I MODELLI 420L E 580L

OSCURANTI TERMICI CABINA

DOTAZIONI OPZIONALI

LUCE ESTERNA

TENDA SEPARAZIONE CABINA

PORTA INGRESSO CON ZANZARIERA

OBLÒ MANUALE MIDI HEKI (50x70cm)

FODERINE COORDINATE PER SEDILI CABINA

PORTAPACCHI ALLUMINIO CON SCALETTA

OSCURANTE BAGNO

PORTA TV LCD CON BASE SCORREVOLE

DUKE/T-LOFT

DOTAZIONI DI GAMMA E OPZIONALI

DOTAZIONI DI SERIE

RISCALDAMENTO E BOILER AD ACCENSIONE ELETTRONICA TRUMA C40

LUCE ESTERNA

LETTI POSTERIORI CON DOGHE

LETTI MANSARDA E BASCULANTI CON DOGHE

OBLÒ MANUALE MIDI HEKI (50x70cm)

OBLÒ POLYPLASTIC (70x35cm) PER MODELLI T-LOFT

OBLÒ CON VENTILAZIONE E ASPIRAZIONE A TRE VELOCITÀ (OPT. MODELLI T-LOFT)

VANO DOCCIA CON PORTA RIGIDA (BOX DOCCIA SEPARATO PER DUKE 55)

3 PRESE 220V

PRESA 12V E 220V, TV-SAT (ESTERNA)

OSCURANTE BAGNO

FINESTRE CON OSCURANTE E ZANZARIERA (SEITZ)

TENDA SEPARAZIONE CABINA

PORTA TV LCD CON BASE SCORREVOLE

DOTAZIONI OPZIONALI

PORTA INGRESSO CON ZANZARIERA

FODERINE COORDINATE PER SEDILI CABINA

GAVONE LATERALE ESTERNO

PORTAPACCHI ALLUMINIO CON SCALETTA

FORNO A GAS (T-LOFT 45, T-LOFT 53 E MODELLI MANSARDATI)

PRINCE

DOTAZIONI DI GAMMA E OPZIONALI

RISCALDAMENTO AD ACCENSIONE ELETTRONICA WEBASTO AIR TOP 3900 EVO
BOILER AD ACCENSIONE ELETTRONICA 10 LITRI
LUCE ESTERNA
FODERINE COORDINATE PER SEDILI CABINA
TESSUTO STANDARD COLORE BEIGE (IN ALTERNATIVA GRIGIO)
PORTA INGRESSO CON ZANZARIERA
FINESTRE CON OSCURANTE E ZANZARIERA (SEITZ)
COLONNE "OPEN VIEW" PER UNA VISIONE PANORAMICA DALLA DINETTE
OBLÒ CON VENTILAZIONE E ASPIRAZIONE A TRE VELOCITÀ
OBLÒ MANUALE MIDI HEKI (50x70cm, MODELLI PROFILÉ)
OBLÒ MANUALE HEKI 2 (60x90cm, MODELLI MANSARDATI)
OBLÒ PANORAMICO SKY DOME SU PROFILÉ
OSCURANTE BAGNO
OBLÒ BAGNO
FORNO A GAS
CAPPASPIRANTE
VANO DOCCIA CON PORTA RIGIDA/BOX DOCCIA
PRESA 12V E 220V, TV-SAT (ESTERNA)
LETTI POSTERIORI CON DOGHE
LETTO MANSARDA CON DOGHE (PER MODELLI MANSARDATI)
GAVONE LATERALE ESTERNO
TENDA SEPARAZIONE CABINA
PORTA TV LCD CON BASE SCORREVOLE

DOTAZIONI OPZIONALI

PORTA INGRESSO CON FINESTRA SEITZ
PORTAPACCHI ALLUMINIO CON SCALETTA
TESSUTO IN ECO PELLE
RETROCAMERA

MAGNUM

DOTAZIONI DI GAMMA E OPZIONALI

RISCALDAMENTO AD ACCENSIONE ELETTRONICA WEBASTO AIR TOP 3900 EVO
BOILER AD ACCENSIONE ELETTRONICA 10 LITRI
LUCE ESTERNA
FODERINE COORDINATE PER SEDILI CABINA
TESSUTO STANDARD COLORE BEIGE (IN ALTERNATIVA GRIGIO)
PORTA INGRESSO CON ZANZARIERA
FINESTRE CON OSCURANTE E ZANZARIERA (SEITZ)
OBLÒ CON VENTILAZIONE E ASPIRAZIONE A TRE VELOCITÀ
OBLÒ MANUALE MIDI HEKI (50x70cm)
OSCURANTE BAGNO
OBLÒ BAGNO
FORNO A GAS
CAPPASPIRANTE
BAGNO CON BOX DOCCIA SEPARATO
PRESA 12V E 220V, TV-SAT (ESTERNA)
LETTI POSTERIORI CON DOGHE
LETTO BASCULANTE CON DOGHE
PORTA TV LCD CON BASE SCORREVOLE
PREDISPOSIZIONE CABLAGGIO RETROCAMERA

DOTAZIONI OPZIONALI

PORTA INGRESSO CON FINESTRA SEITZ
PORTAPACCHI ALLUMINIO CON SCALETTA
TESSUTO IN ECO PELLE
RETROCAMERA

GAMMA BARON MODELLI MANSARDATI

BARON 37

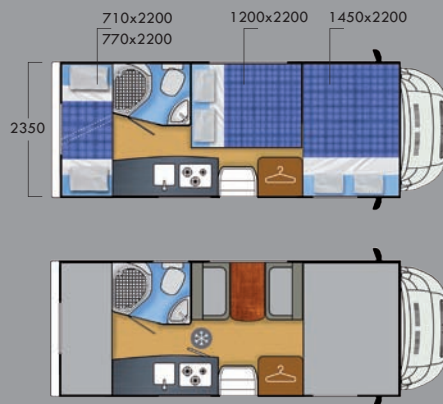
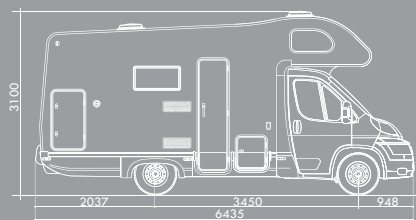

Posti omologati CE

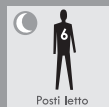

Posti letto



Doccia separata



Garage con letto convertibile



Frigorifero 117lt.

MOTORIZZAZIONI DISPONIBILI	DUCATO 2.200 cc.	DUCATO 2.300 cc.
Passo mm	3450	3450
Massa complessiva a pieno carico kg.	3500	3500
Massa complessiva in ordine di marcia kg.	2952	2967
Carico utile kg.	548	533
Massa rimorchiabile kg. (frenata)(OPT)	2000	2000

BARON 46

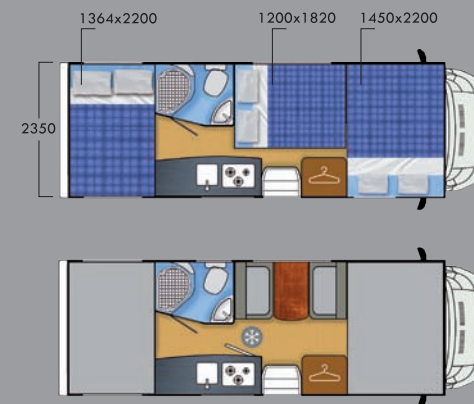
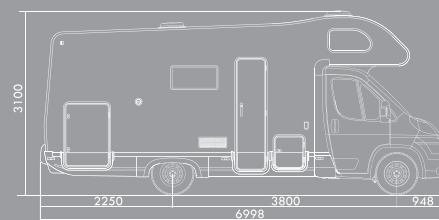

Posti omologati CE

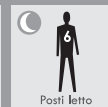

Posti letto



Doccia separata

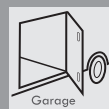

Garage



Frigorifero 117lt.

MOTORIZZAZIONI DISPONIBILI	DUCATO 2.200 cc.	DUCATO 2.300 cc.
Passo mm	3800	3800
Massa complessiva a pieno carico kg.	3500	3500
Massa complessiva in ordine di marcia kg.	2937	2952
Carico utile kg.	563	548
Massa rimorchiabile kg. (frenata)(OPT)	2000	2000

BARON 47D

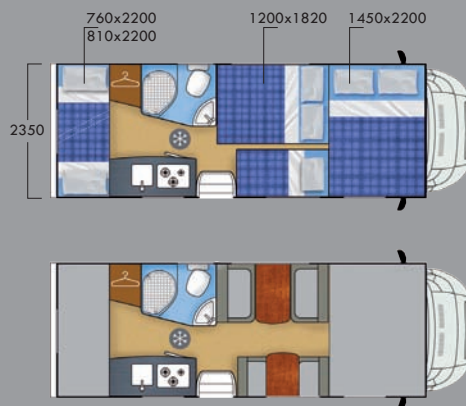
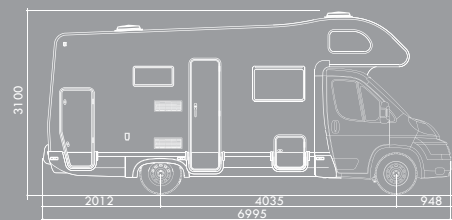

Posti omologati CE

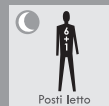

Posti letto



Doccia separata



Garage con letto convertibile



Frigorifero 117lt.

MOTORIZZAZIONI DISPONIBILI	DUCATO 2.200 cc.	DUCATO 2.300 cc.
Passo mm	4035	4035
Massa complessiva a pieno carico kg.	3500	3500
Massa complessiva in ordine di marcia kg.	2892	2907
Carico utile kg.	608	593
Massa rimorchiabile kg. (frenata)(OPT)	2000	2000

GAMMA BARON MODELLI SEMI-INTEGRALI

BARON 420L

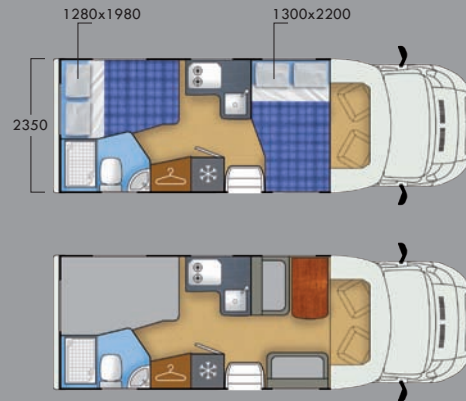
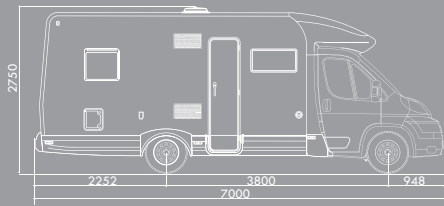

Posti omologati CE



Posti letto



Doccia separata



Frigorifero 150lt.

MOTORIZZAZIONI DISPONIBILI	DUCATO 2.200 c.c.	DUCATO 2.300 c.c.
Passo mm	3800	3800
Massa complessiva a pieno carico kg.	3300	3300
Massa complessiva in ordine di marcia kg.	2916	2931
Carico utile kg.	384	369
Massa rimorchiabile kg. (frenata)(OPT)	2000	2000

BARON 580L

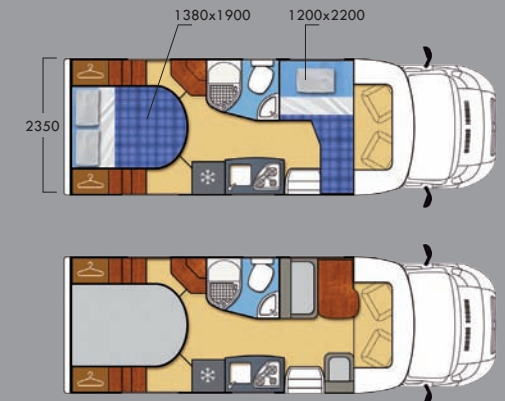
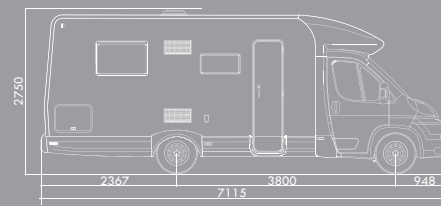

Posti omologati CE



Posti letto



Doccia separata



Frigorifero 150lt.

MOTORIZZAZIONI DISPONIBILI	DUCATO 2.200 c.c.	DUCATO 2.300 c.c.
Passo mm	3800	3800
Massa complessiva a pieno carico kg.	3300	3300
Massa complessiva in ordine di marcia kg.	2775	2790
Carico utile kg.	525	510
Massa rimorchiabile kg. (frenata)(OPT)	2000	2000

GAMMA DUKE MODELLI MANSARDATI

DUKE 46

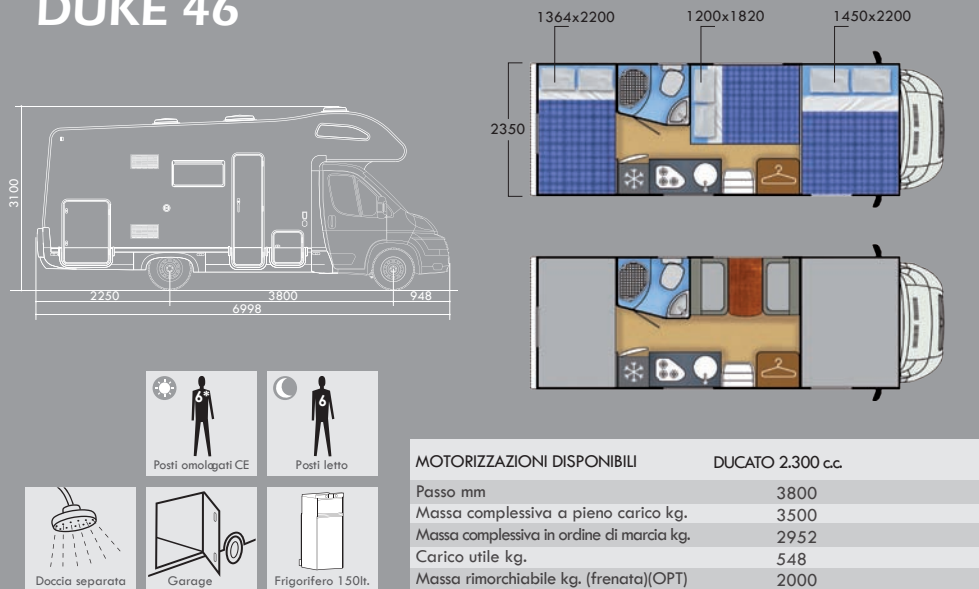

*IN ALCUNI MERCATI È PREVISTA L'OMOLOGAZIONE A POSTI RIDOTTI

DUKE 55

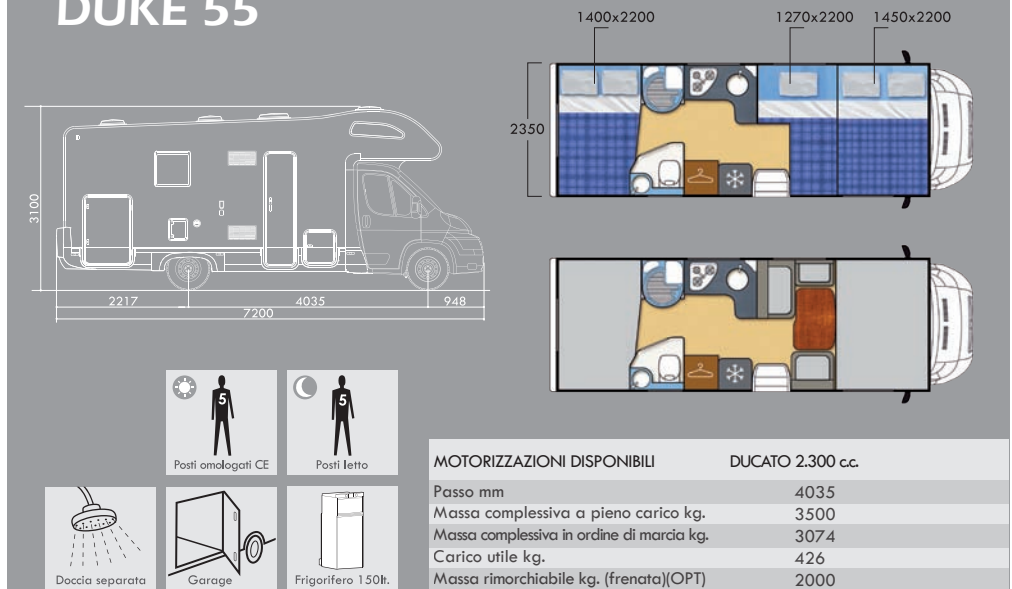

DUKE 57D

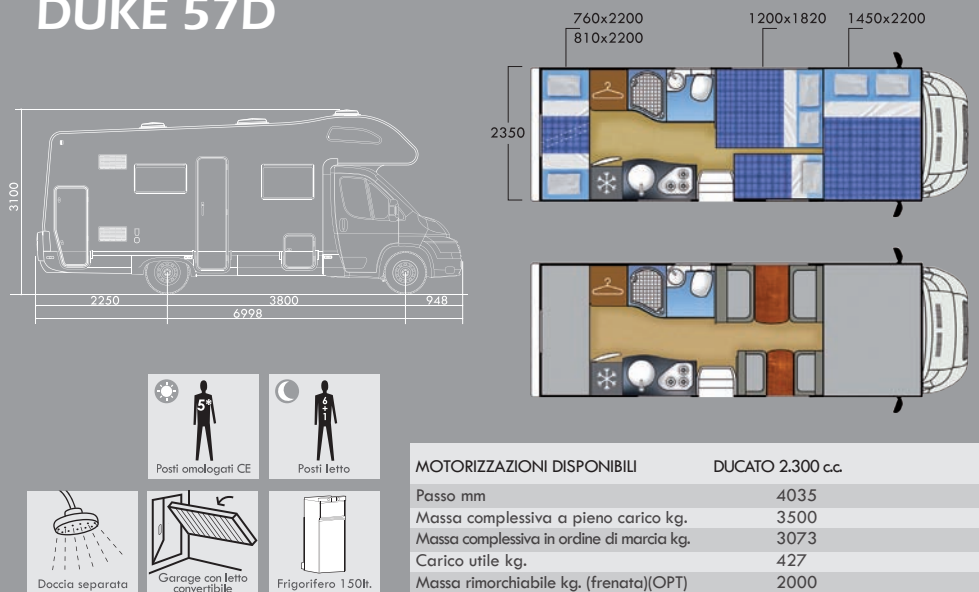

*IN ALCUNI MERCATI È PREVISTA L'OMOLOGAZIONE A POSTI RIDOTTI

GAMMA T-LOFT MODELLI SEMI-INTEGRALI

T-LOFT 31

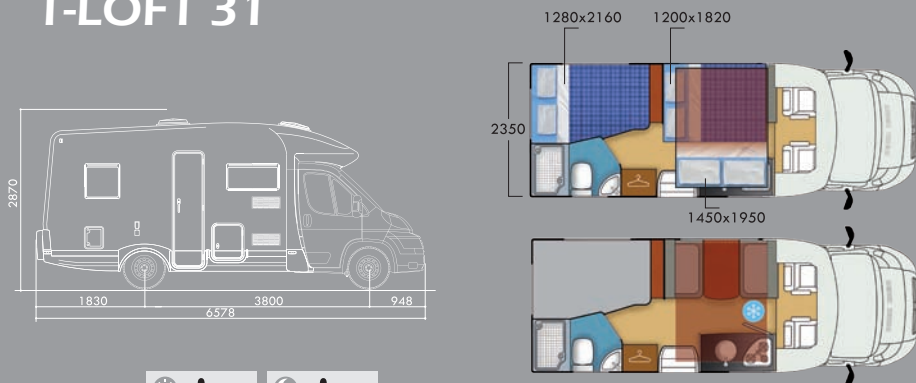

MOTORIZZAZIONI DISPONIBILI	DUCATO 2.300 c.c.
Passo mm	3800
Massa complessiva a pieno carico kg.	3500
Massa complessiva in ordine di marcia kg.	2881
Carico utile kg.	619
Massa rimorchiabile kg. (frenata)(OPT)	2000

T-LOFT 45

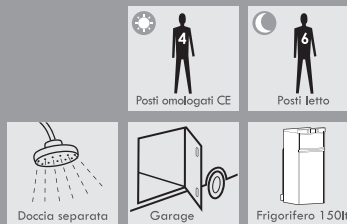
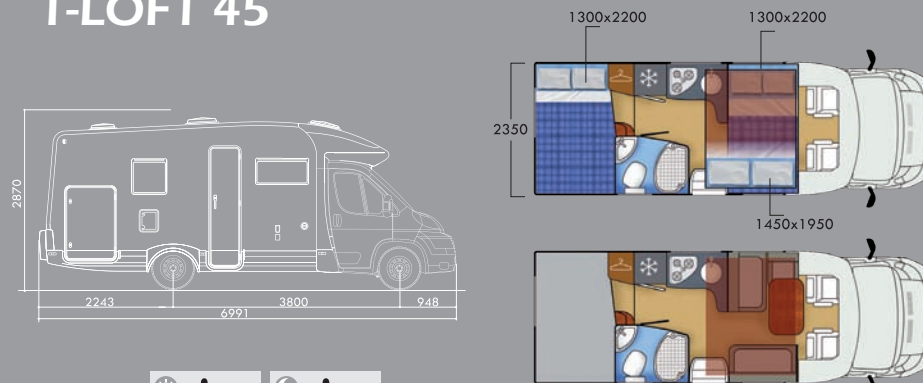

MOTORIZZAZIONI DISPONIBILI	DUCATO 2.300 c.c.
Passo mm	3800
Massa complessiva a pieno carico kg.	3500
Massa complessiva in ordine di marcia kg.	2962
Carico utile kg.	538
Massa rimorchiabile kg. (frenata)(OPT)	2000

T-LOFT 53

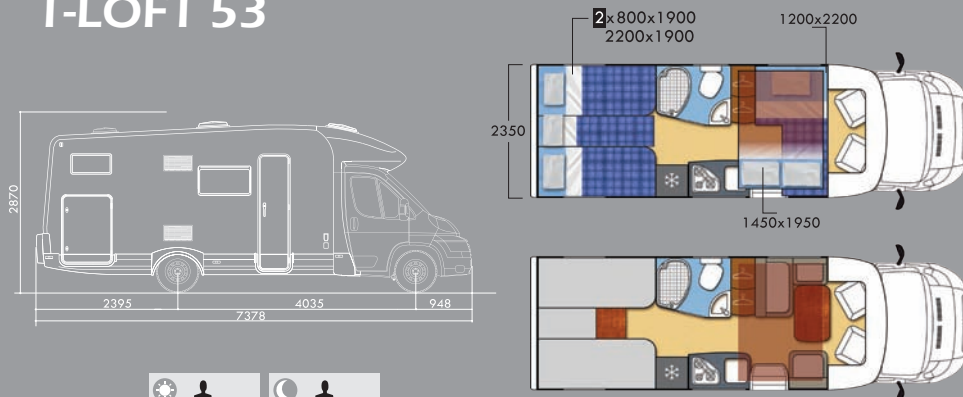

MOTORIZZAZIONI DISPONIBILI	DUCATO 2.300 c.c.
Passo mm	4035
Massa complessiva a pieno carico kg.	3500
Massa complessiva in ordine di marcia kg.	3105
Carico utile kg.	395
Massa rimorchiabile kg. (frenata)(OPT)	2000

T-LOFT 58

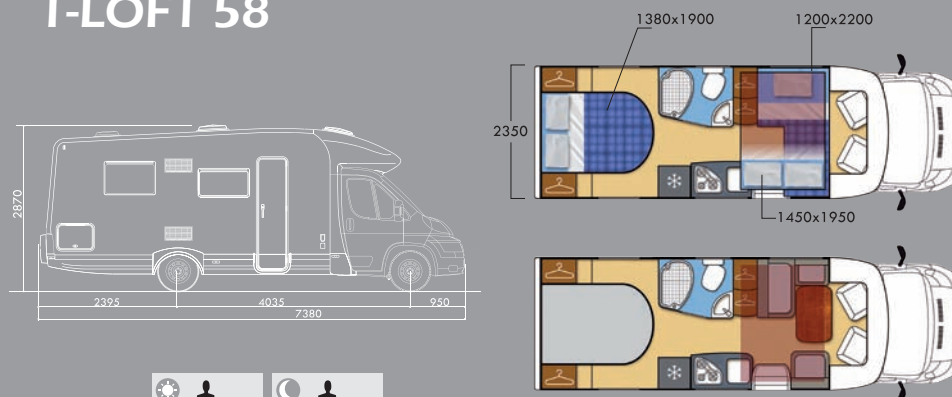

MOTORIZZAZIONI DISPONIBILI	DUCATO 2.300 c.c.
Passo mm	4035
Massa complessiva a pieno carico kg.	3042
Massa complessiva in ordine di marcia kg.	2787
Carico utile kg.	458
Massa rimorchiabile kg. (frenata)(OPT)	2000

GAMMA PRINCE MODELLI MANSARDATI

PRINCE 46

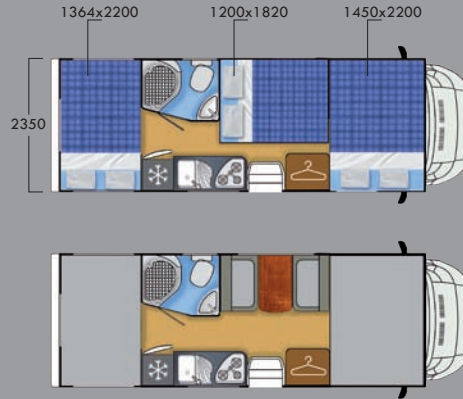
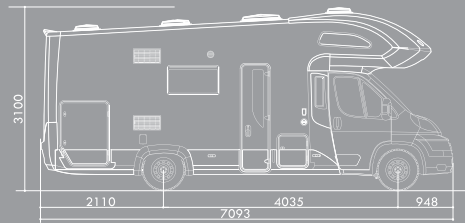

*4 posti omologati nella versione 160CV



MOTORIZZAZIONI DISPONIBILI	DUCATO 2.300 cc.	DUCATO 3.000 cc.
Passo mm	4035	4035
Massa complessiva a pieno carico kg.	3500	3500
Massa complessiva in ordine di marcia kg.	3066	3161
Carico utile kg.	434	339
Massa rimorchiabile kg. (frenata)(OPT)	2000	2000

PRINCE 47

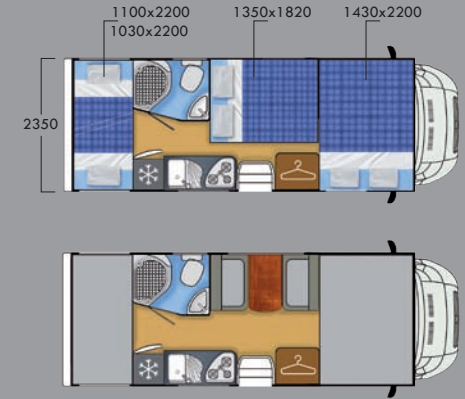
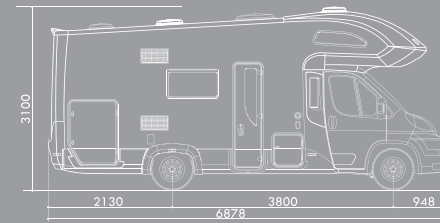

*4 posti omologati nella versione 160CV



MOTORIZZAZIONI DISPONIBILI	DUCATO 2.300 cc.	DUCATO 3.000 cc.
Passo mm	3800	3800
Massa complessiva a pieno carico kg.	3500	3500
Massa complessiva in ordine di marcia kg.	3068	3163
Carico utile kg.	432	337
Massa rimorchiabile kg. (frenata)(OPT)	2000	2000

PRINCE 55L

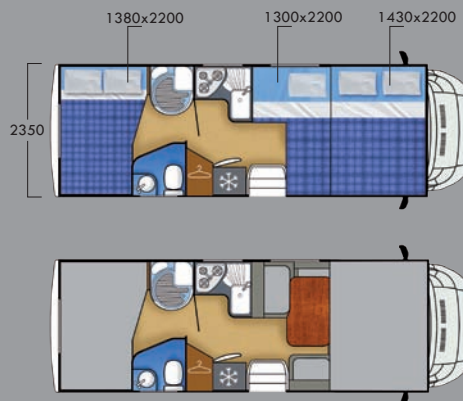
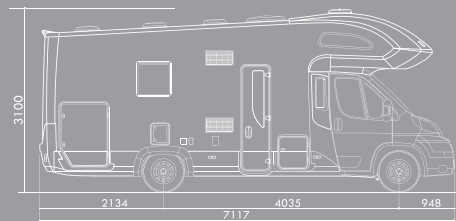

MOTORIZZAZIONI DISPONIBILI	DUCATO 2.300 cc.	DUCATO 3.000 cc.
Passo mm	4035	4035
Massa complessiva a pieno carico kg.	3500	3500
Massa complessiva in ordine di marcia kg.	3130	3160
Carico utile kg.	370	340
Massa rimorchiabile kg. (frenata)(OPT)	2000	2000

PRINCE 57

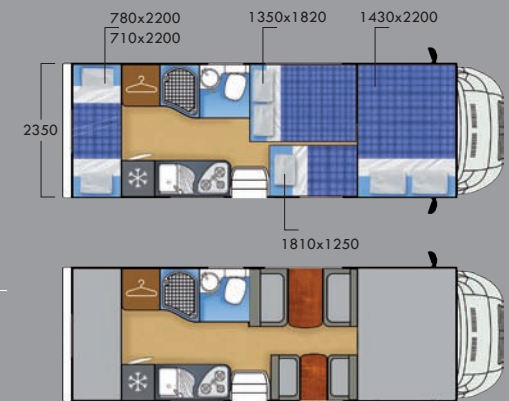
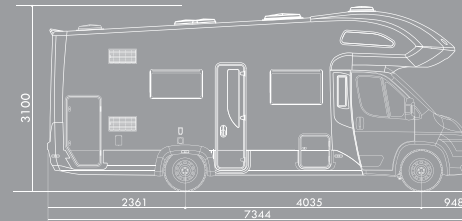

*4 posti omologati nella versione 160CV



MOTORIZZAZIONI DISPONIBILI	DUCATO 2.300 cc.	DUCATO 3.000 cc.
Passo mm	4035	4035
Massa complessiva a pieno carico kg.	3500	3500
Massa complessiva in ordine di marcia kg.	3073	3158
Carico utile kg.	427	342
Massa rimorchiabile kg. (frenata)(OPT)	2000	2000

GAMMA PRINCE MODELLI SEMI-INTEGRALI

PRINCE 530L

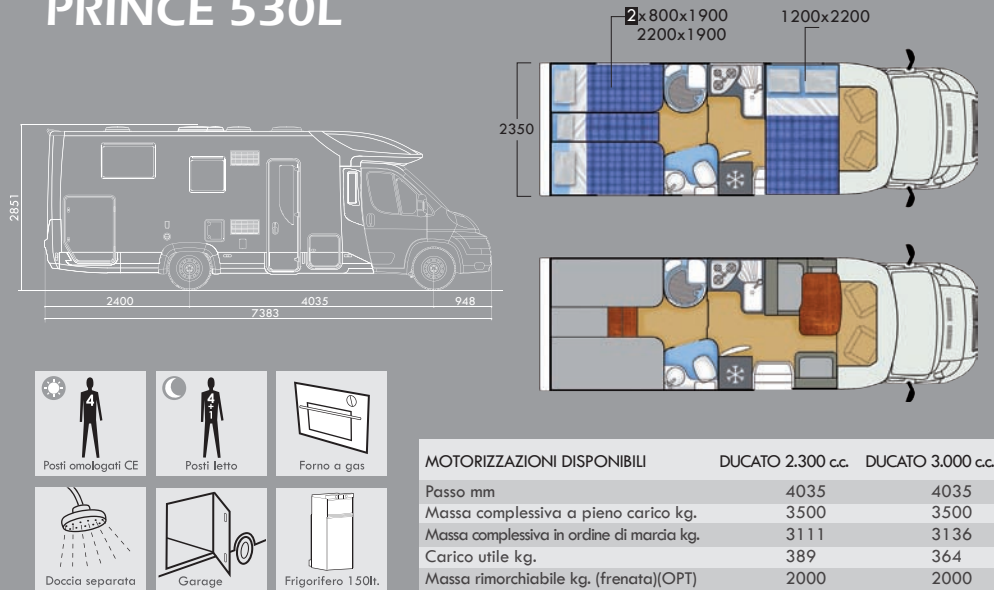

PRINCE 570L

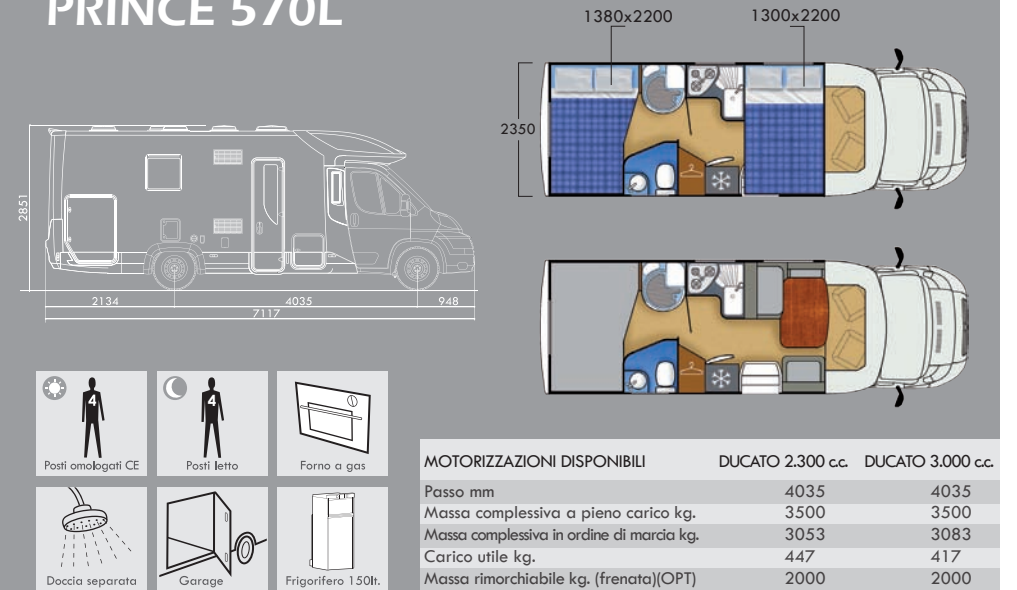

PRINCE 580L

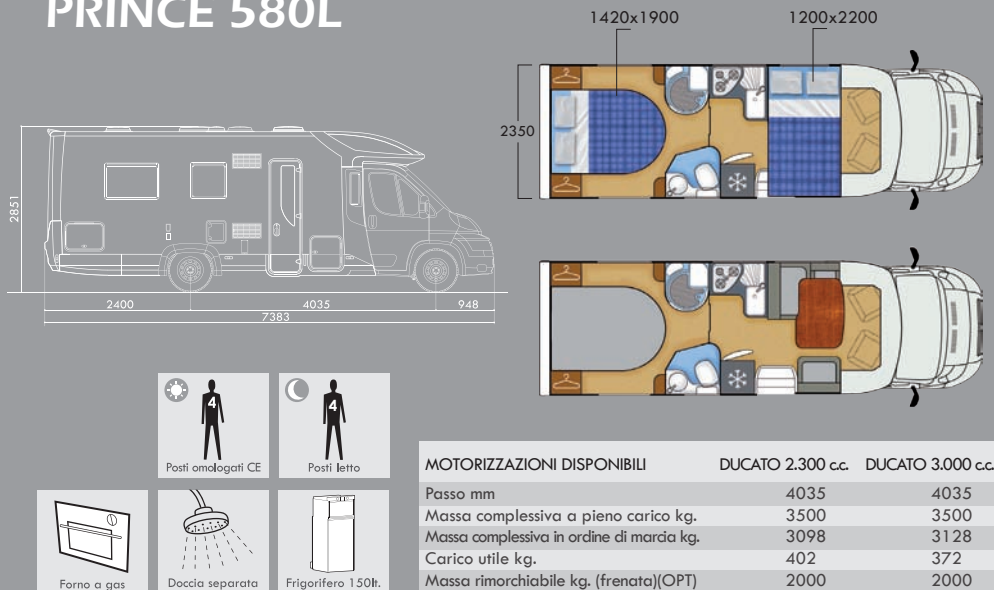

GAMMA PRINCE MODELLI SEMI-INTEGRALI

PRINCE 581L

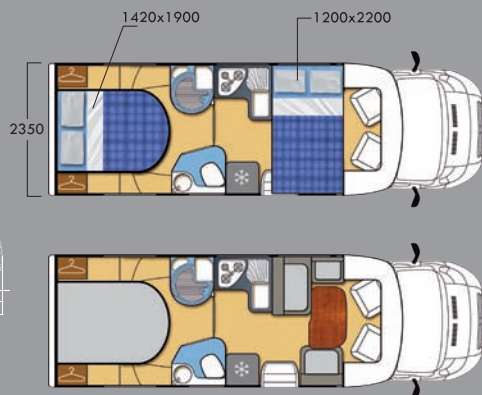
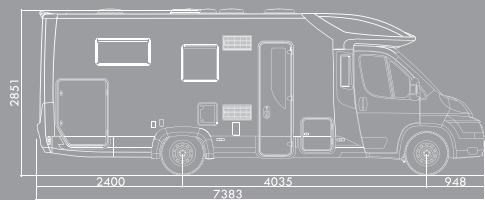

Posti omologati CE



Posti letto



Forno a gas



Doccia separata

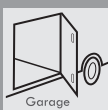

Garage



Frigorifero 150lt.

MOTORIZZAZIONI DISPONIBILI	DUCATO 2.300 cc.	DUCATO 3.000 cc.
Passo mm	4035	4035
Massa complessiva a pieno carico kg.	3500	3500
Massa complessiva in ordine di marcia kg.	3094	3124
Carico utile kg.	406	376
Massa rimorchiabile kg. (frenata)(OPT)	2000	2000

PRINCE 590L

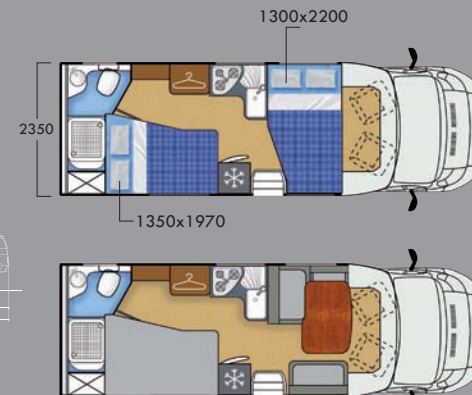
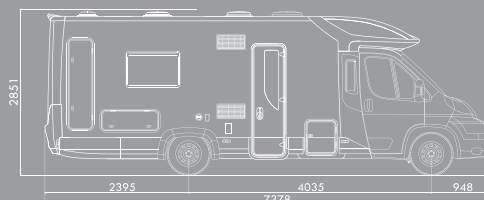

Posti omologati CE



Posti letto



Forno a gas



Doccia separata



Frigorifero 150lt.

MOTORIZZAZIONI DISPONIBILI	DUCATO 2.300 cc.	DUCATO 3.000 cc.
Passo mm	4035	4035
Massa complessiva a pieno carico kg.	3500	3500
Massa complessiva in ordine di marcia kg.	3080	3110
Carico utile kg.	420	390
Massa rimorchiabile kg. (frenata)(OPT)	2000	2000

GAMMA MAGNUM MODELLI MOTORHOME

MAGNUM 30

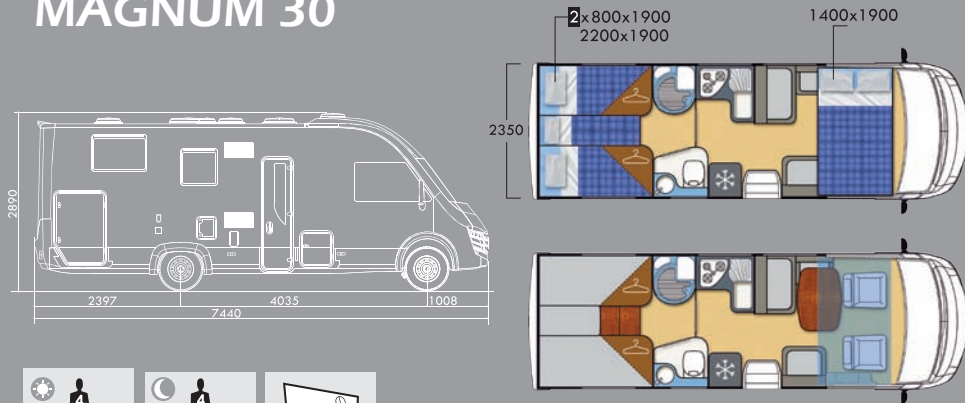

MOTORIZZAZIONI DISPONIBILI	DUCATO 2.300 c.c.	DUCATO 3.000 c.c.
Passo mm	4035	4035
Massa complessiva a pieno carico kg.	3500	3500
Massa complessiva in ordine di marcia kg.	3129	3159
Carico utile kg.	371	341
Massa rimorchiabile kg. (frenata)(OPT)	*	*

*IN FASE DI OMOLOGAZIONE

MAGNUM 70

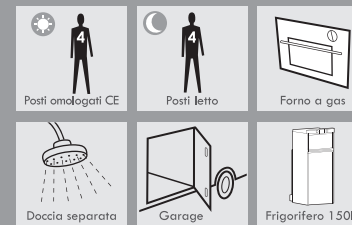
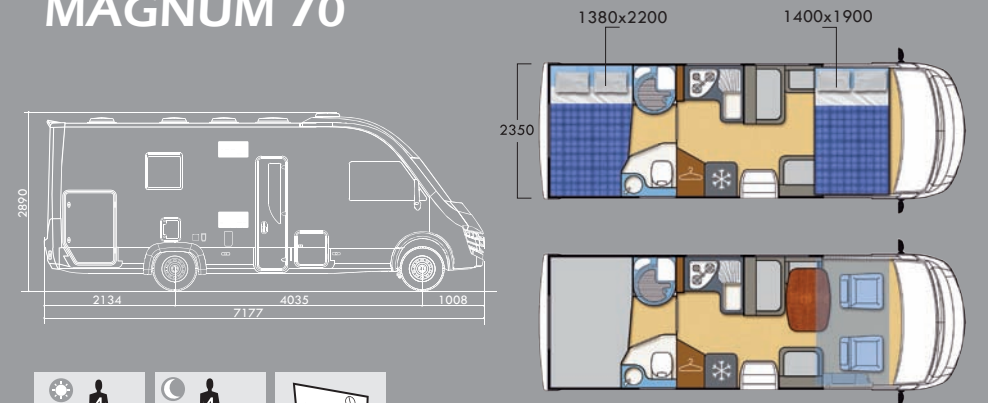

MOTORIZZAZIONI DISPONIBILI	DUCATO 2.300 c.c.	DUCATO 3.000 c.c.
Passo mm	4035	4035
Massa complessiva a pieno carico kg.	3500	3500
Massa complessiva in ordine di marcia kg.	3126	3156
Carico utile kg.	374	344
Massa rimorchiabile kg. (frenata)(OPT)	*	*

*IN FASE DI OMOLOGAZIONE

LE MASSE ESPOSTE IN QUESTO CATALOGO FANNO RIFERIMENTO A QUANTO CONTENUTO NELLA DIRETTIVA EUROPEA 95/48/CE ED ALLA NORMA UNI EN 1646 – 2.

MASSA IN ORDINE DI MARCIA

COMPRENDE IL PESO DEL VEICOLO DI BASE A VUOTO, IL CONDUCENTE, IL CARBURANTE, I LUBRIFICANTI, IL LIQUIDO DEL RAFFREDDAMENTO, GLI ATTREZZI, LE BOMBOLE DEL GAS ED IL SERBATOIO ACQUE CHIARE. ALCUNI MODELLI HANNO LA LIMITAZIONE SUL CARICO ACQUE CHIARE. (VEDI ETICHETTA APPLICATA SU PUNTO DI CARICO).

L'IMPIANTO DELL'ACQUA POTABILE È CONFORME ALLO STATO DELLA TECNICA 03/2009 (NORMA 2002/72/CEE).

CARICO UTILE

È COSTITUITO DALLA DIFFERENZA TRA LA MASSA COMPLESSIVA AMMESSA E LA MASSA IN ORDINE DI MARCIA. COMPRENDE GLI ELEMENTI AI FINI ABITATIVI, I PASSEGGERI TRASPORTATI DEFINITI DAL COSTRUTTORE SENZA IL CONDUCENTE, GLI EFFETTI PERSONALI. TUTTE LE MASSE ED I CARICHI DEL VEICOLO A VUOTO, CONFORMEMENTE ALLA DIRETTIVA 95/48/CE, HANNO UNA TOLLERANZA DI $\pm 5\%$. IL PESO DEGLI ACCESSORI NON DI SERIE NON È INCLUSO NELLA MASSA IN ORDINE DI MARCIA RIPORTATE IN QUESTO CATALOGO. ACCESSORI E DISPOSITIVI ADDIZIONALI LIMITANO IL CARICO UTILE DI UNA QUANTITÀ PARI AL LORO PESO.

IN CASO DI INSTALLAZIONE DI APPENDICI SUPPLEMENTARI (GANCIO DI TRAINO O PORTAMOTO), PUÒ VARIARE IL NUMERO DEI POSTI OMOLOGATI. LE NORMATIVE E LE ESIGENZE DI OGNI PAESE POSSONO PORTARE DELLE MODIFICHE ALLE CARATTERISTICHE DELLA PRESENTE TABELLA. IL NUMERO DEI POSTI OMOLOGATI PUÒ VARIARE IN DIPENDENZA DELLE NORMATIVE DEI SINGOLI STATI IN MATERIA DI CIRCOLAZIONE.

LA SEA S.P.A. – ELNAGH SI RISERVA IL DIRITTO DI MODIFICARE SENZA PREAVVISO LE CARATTERISTICHE E L'ARREDAMENTO DI OGNI SUO MODELLO; TUTTI I DATI CONTENUTI NEL PRESENTE OPUSCOLO SONO QUINDI DA CONSIDERARSI INDICATIVI E NON VINCOLANTI.



SEA, UNA SOLIDA REALTÀ INDUSTRIALE



SEA è uno dei principali produttori Europei di camper e raggruppa marchi leader nel settore, attivi da oltre 60 anni. La notorietà dei marchi SEA ed il loro costante apprezzamento negli anni, insieme al suo vastissimo parco circolante, garantiscono ai nostri clienti una eccezionale tenuta del valore dei loro veicoli nel tempo.

SEA, grazie ad una solida struttura organizzativa, è in grado di garantire prodotti e servizi di qualità eccellente, attenzione e professionalità: SEA soddisfa le aspettative del cliente con competenza e dedizione. Il processo costante di ricerca e selezione dei migliori fornitori, unitamente alla nostra qualità garantita da test e controlli lungo tutta la filiera produttiva garantiscono ai nostri veicoli una grande affidabilità.

La produzione dei veicoli del gruppo SEA avviene in impianti modernissimi attraverso un processo produttivo industrializzato dove anche l'abilità del singolo operatore nella cura artigianale del dettaglio crea il valore aggiunto e la differenza qualitativa. Il lavoro svolto quotidianamente dai centri di ricerca e sviluppo consentono di mettere a punto nuove tecnologie e soluzioni innovative che permettono un costante miglioramento delle performance dei prodotti.



POLO INDUSTRIALE POGGIBONSI (TOSCANA)

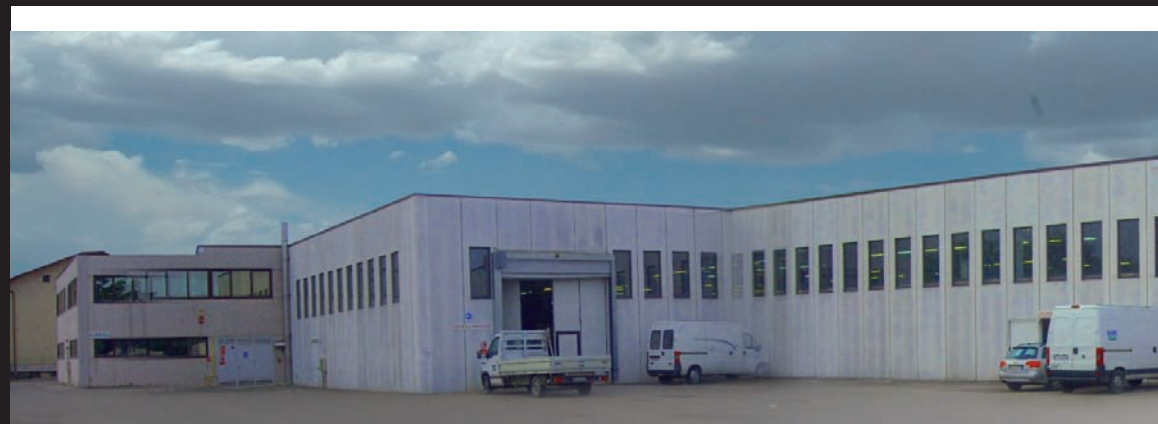

POLO INDUSTRIALE SAN GIUSTINO (PERUGIA)

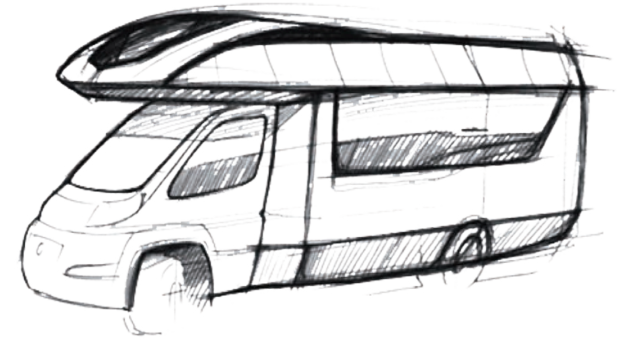

POLO INDUSTRIALE TRIVOLZIO (LOMBARDIA)





La SEA S.p.A. - Elnagh si riserva il diritto di modificare senza preavviso le caratteristiche e l'arredamento di ogni suo modello; tutti i dati contenuti nel presente opuscolo sono quindi da considerarsi indicativi e non vincolanti.



V.le Dell' Industria, 6 - 27020 Trivulzio (PV) Italia - Tel.+39 03824530.1 - Fax+39 03824530.550 - info@elnagh.it

www.elnagh.it